

BERARMA

oleodinamica

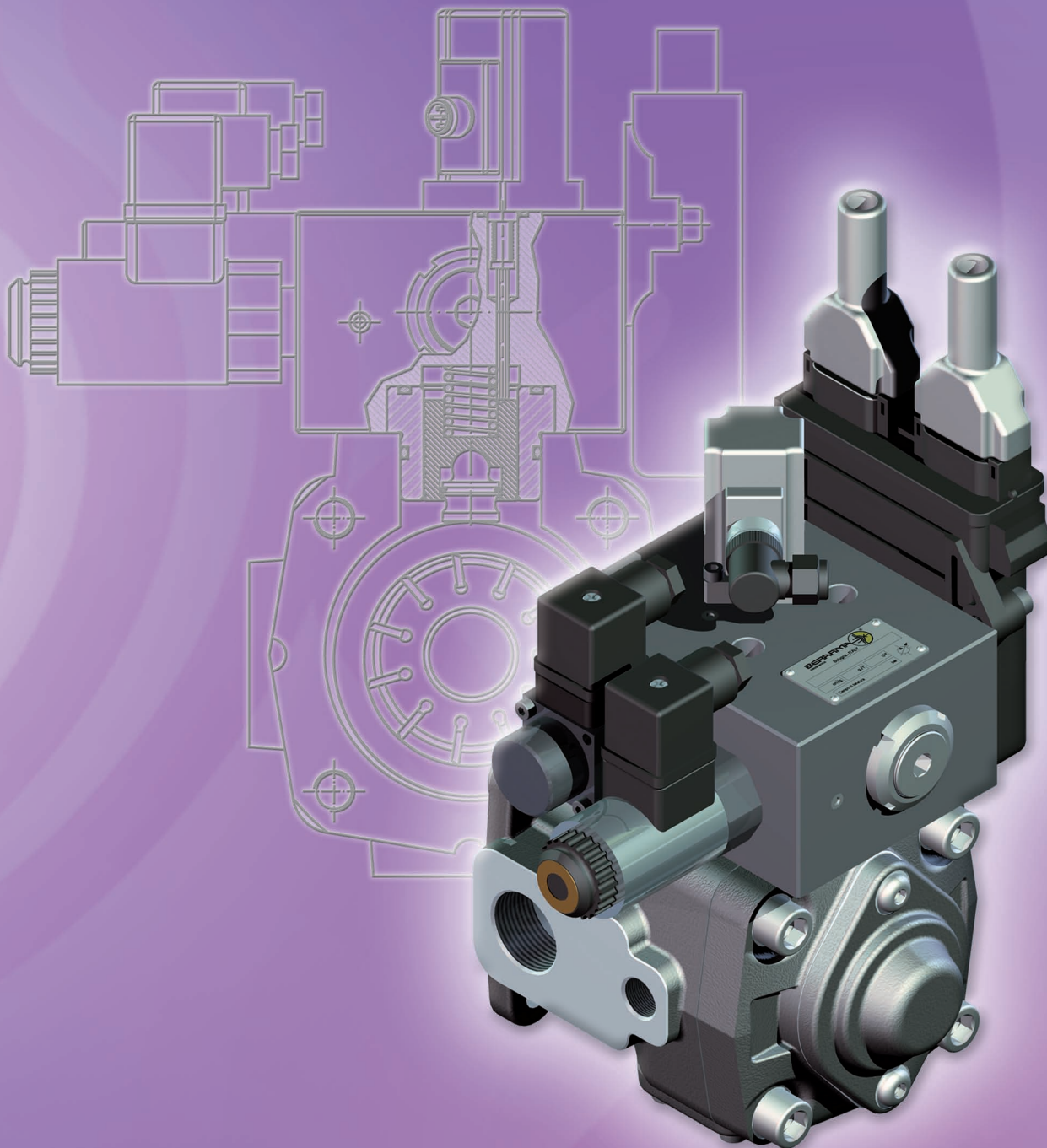

VARIABLE DISPLACEMENT VANE PUMP 

TYPE 02 PHC

geometric displacement 25 - 50 - 100 cm³

max working pressure 160 bar electronic proportional flow-rate and pressure adjustment

GENERAL DESCRIPTION	Page	4
TECHINICAL DATA	Page	5
ORDERING CODE	Page	6
DIGITAL ELECTRONIC DRIVER CHARACTERISTICS	Page	7
FLOW-RATE CONTROL	Page	8
PRESSURE CONTROL – TYPE “S”	Page	9
PRESSURE CONTROL – TYPE “P1”	Page	10
PRESSURE CONTROL – TYPE “P2”	Page	11
PRESSURE CONTROL – TYPE “P3”	Page	12
POWER LIMITER CONTROL – TYPE “P4”	Pages	13-14
BERARMA PHC SOFTWARE	Page	15
ELECTRICAL CONNECTIONS	Page	16
DIMENSIONS	Pages	17-19
INSTALLATION INSTRUCTIONS	Pages	20-21
ASSEMBLING	Page	22

As a result of the constant research activity carried out in order to introduce into the market innovative products defined by a high technological content and reliability, BERARMA has launched the **new series of PHC variable displacement vane pumps**.

The new series of PHC pumps is equipped with a digital P/Q controller that, in closed loop, permits the combined pressure and flow-rate adjustment.

Features and characteristics :

- Digital electronic driver factory presetted and integrated into the pump
- High performances (as flow-rate and pressure linearity and hysteresis)
- Excellent dynamic of the adjustment system
- Possibility to optimize the pump performances by using “Berarma PHC Software”
- RS232 serial communication interface
- Economy and simplification of the hydraulic system
- Low noise level
- Energy saving

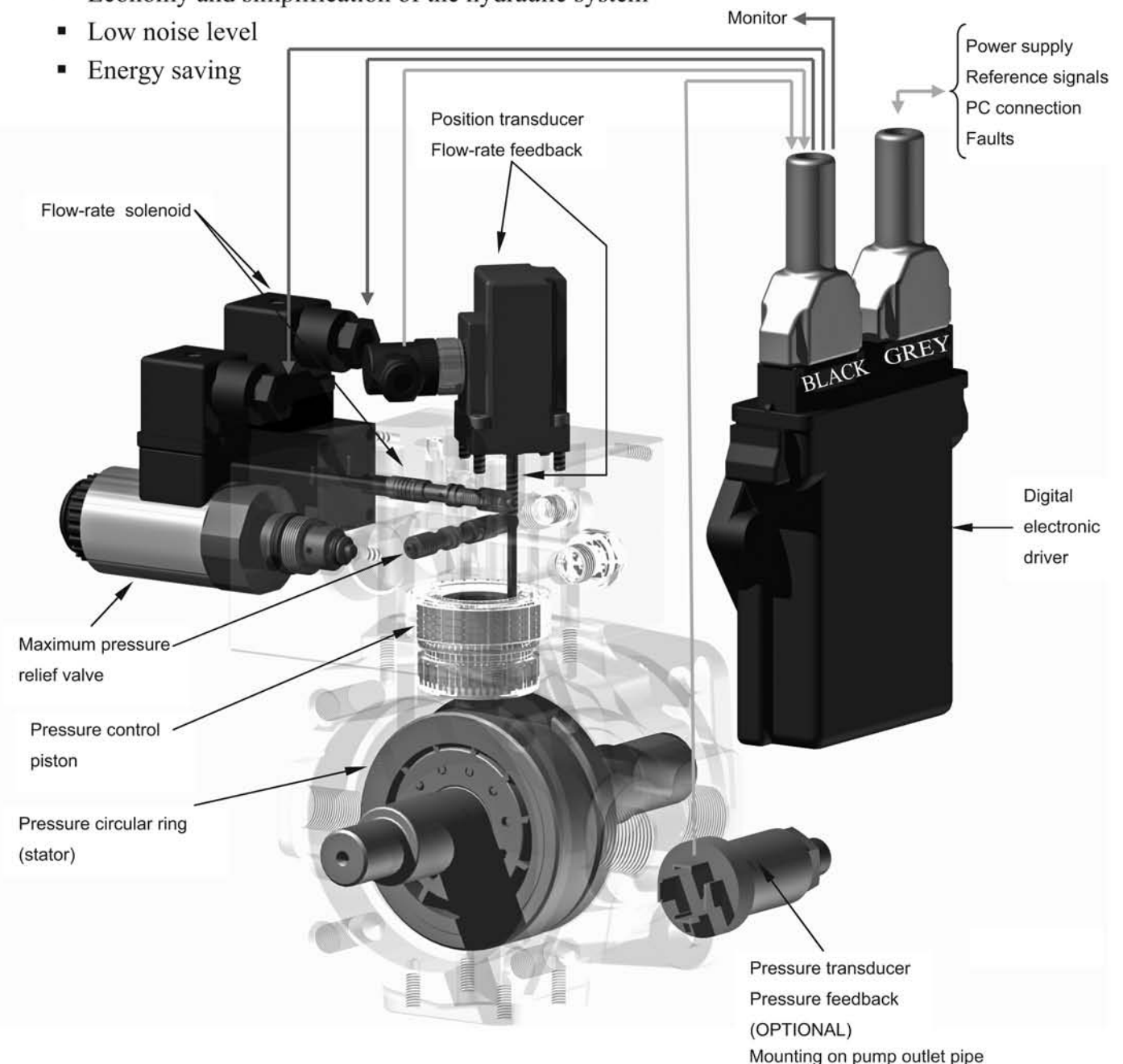

Pump type – Nominal size	PHC - 1	PHC - 2	PHC - 3
Geometric displacement according to UNI ISO 3662 (cm ³ /r)	25	50	100
Actual displacement (cm ³ /r)	26.9	53.1	105.5
Maximum working pressure (bar)	160	160	150
Control pressure setting (bar)	30 – 160	30 – 160	30 – 150
Minimum pressure for flow-rate adjustment (bar)	30 (*)		
Mounting flange and port connections	F - (UNI ISO 3019/2) 4 bolt flange GAS BSP (UNI ISO 228/1) threads	F – (UNI ISO 3019/2) 4 bolt flange Inlet/Outlet ports SAE J518 3000 series flanges with 4 metric mounting bolts Drain port GAS BSP (UNI ISO 228/1) threads	
Allowed maximum drain port pressure (bar)	1		
Inlet pressure (bar-abs)	0.8 – 1.5		
Speed range (rpm)	800 – 1800		
Rotation direction (viewed from shaft end)	R – Right hand (clockwise)		
Loads on drive shaft	NO RADIAL OR AXIAL LOADS ALLOWED		
Maximum torque on primary shaft (Nm)	197	400	740
Combined pumps	For different solutions of combined pumps, please consult “Variable displacement vane pump type 02 PSP” catalogue and/or contact Berarma Technical-Sale Service		
Power consumption at 1450 rpm and at maximum pressure and displacement (kW)	11.5	22.5	42.5
Hydraulic fluid	Mineral oil HM according to ISO 6743/4 HLP according to DIN 5124/2 Organic ester HFD-U according to ISO 6743/4 (Quintolubric 888) In case of different fluids please contact Berarma Technical-Sale Service		
Viscosity range (cSt, mm ² /s)	22 – 68		
Viscosity in starting operation in full flow condition (cSt, mm ² /s)	400 max		
Viscosity index according to ISO 2909	100 min		
Inlet fluid temperature range (°C)	-10 / +50		
Fluid contamination level	18/16/13 according to ISO 4406/99 CLASS 7 according to NAS 1638		
Pump weight (Kg)	16	36	48

(*) NOTE: For working pressure below 30 bar please contact Berarma Technical-Sale Service

For further informations and/or different operating conditions, please consult “Variable displacement vane pump type 02 PSP” catalogue and/or contact Berarma Technical-Sale Service

SERIES	DENOMINATION	SIZE	DISPLACEMENT	FLANGE - PORT CONNECTIONS	PRESSURE SETTING	ROTATION	SEALS	PRESSURE CONTROLS	MAX PRESSURE	PRESSURE REF. SIGNAL	FLOW-RATE REF. SIGNAL
02	PHC	1	25	F	H	R	M	P2	160	X	A

02 – Pump Series
PHC – Pump denomination
1 – Pump size 1 , 2 , 3
25 – Pump displacement 25 , 50 , 100 cm³/r
F – UNI ISO 3019/2 4 bolt flange
 GAS BSP UNI ISO 228/1 threads
 SAE J518 3000 series flanges
H – 30 ÷ 160 bar (size 1, 2)
 30 ÷ 150 bar (size 3)
R – Right hand (clockwise)
M – NBR seals
E – FPM (Viton) seals
S – One adjustable stage of pressure
P1 - On-Off pressure control
P2 - Open Loop proportional pressure control
P3 - Closed Loop proportional pressure control
P4 - Power limiter control (please specify kW)
160 – Maximum pressure setting: 160 bar (size 1, 2); 150 bar (size 3)
X – 0 ÷ 10 VDC
Z – 4 ÷ 20 mA
A – 0 ÷ 10 VDC
B – 0 ÷ 5 VDC
C – 4 ÷ 20 mA

- Digital electronic driver factory presetted and integrated into the pump
- Flow-rate, pressure and power limiter control realized with P.I.D. technology
- High performances (as flow-rate and pressure linearity and hysteresis)
- Flow-rate and pressure monitor signals output
- Faults messages (example: short circuit on flow-rate and/or pressure solenoid current)
- Possibility to optimize the pump performances by using “Berarma PHC Software”
- RS232 serial communication interface

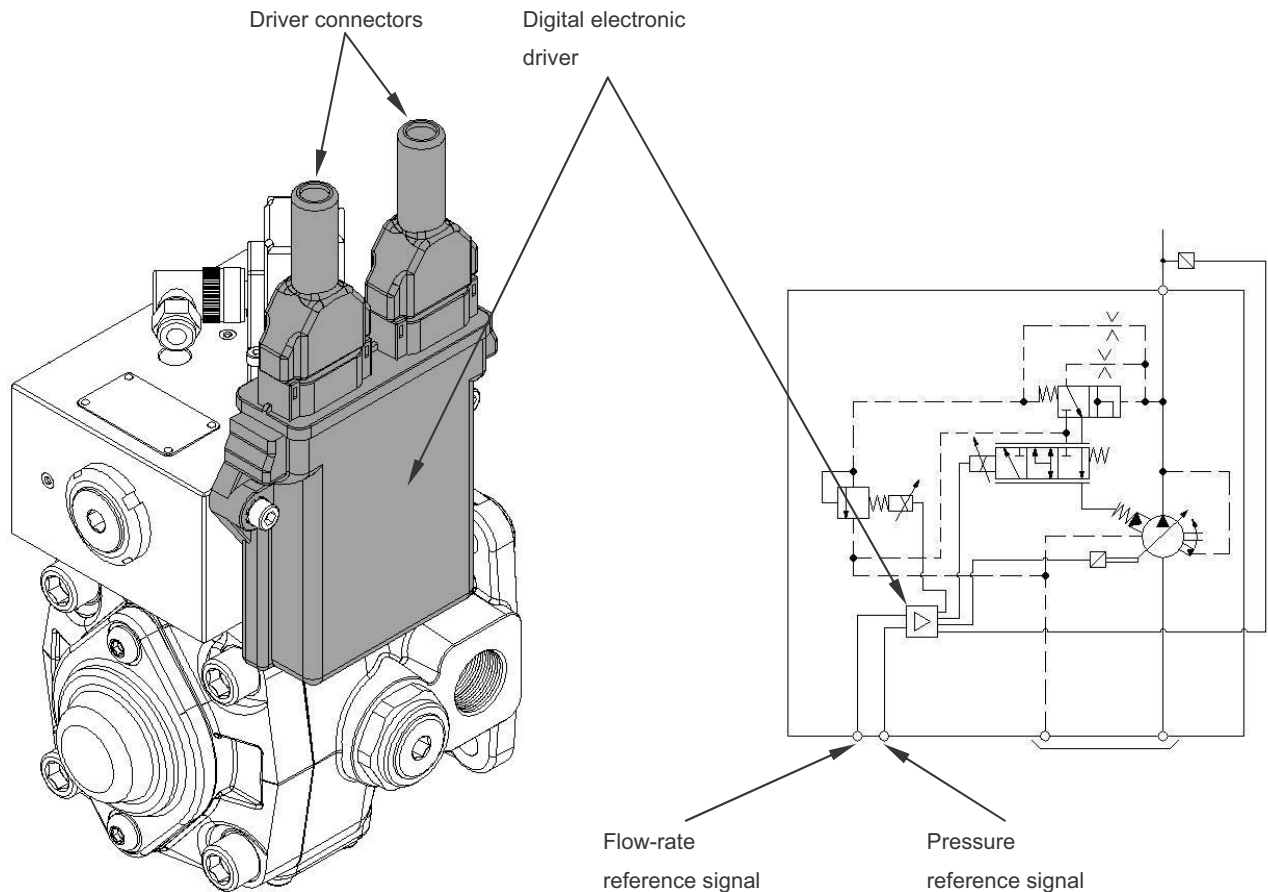

PHC Pump Control Options	Flow-Rate	Closed Loop Proportional Flow-Rate Control
	Pressure	S - Mechanical Pressure Control P1 - Pressure Control option On-Off P2 - Proportional Pressure Control option Open Loop P3 - Proportional Pressure Control option Closed Loop
	Power	P4 - Power Limiter Control
Power Supply	Stabilized +24VDC ±10% (ripple max 2V _{pp})	
Operating ambient temperature range	0 ÷ +50°C	
Format	Sealed box – Protection IP65 (EN 60529) NOTE: In order to guarantee the box sealed it is necessary to plug the connections not wired with the supplied plastic pins (see page 16)	

The pump flow-rate is regulated by a proportional solenoid valve integrated into the pump (**EVQ**).

The electronic system, carried out in **closed loop** feedback by a position transducer, controls the pressure circular ring (stator) eccentricity value according to the input reference signal, and consequently the pump flow-rate value (see fig. on page 4).

Note on cables and connectors (see page 16):

Electronic driver → Flow-rate solenoid (**EVQ**) included

Electronic driver → Position transducer included

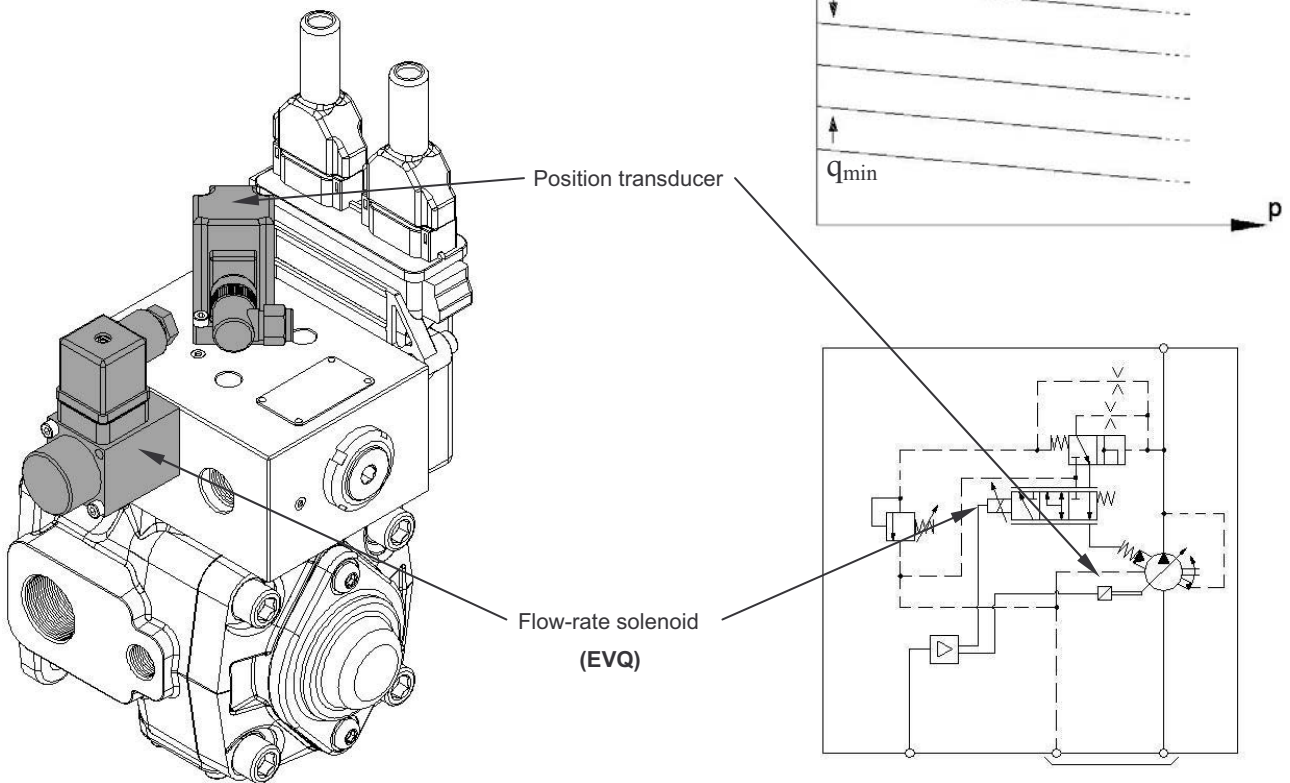

Flow-Rate Control Reference Input Signal Options		A - 0 ÷ 10 VDC
		B - 0 ÷ 5 VDC
		C - 4 ÷ 20 mA
Analog Input Reference Signal Impedance	Voltage signal	>50 kΩ
	Current signal	200 Ω
Max solenoid current		0.68 A
Solenoid impedance		24.6 Ω
Position Transducer Characteristics	Power Supply	24VDC ±10%
	Current Consumption	< 50mA
	Output Voltage	6 ÷ 9 VDC

Linearity	≤ 1.5%		approximate values established on Berarma test machine related to 1500 rpm, mineral oil HM according to ISO 6743/4, ISO VG 32 according to ISO 3448, temperature 48°C
Hysteresis	≤ 1%		
Repeatability	≤ 0.5%		
Response time with stepped reference signal variation	Increasing step	≤ 150 ms	
	Decreasing step	≤ 90 ms	

Mechanical pressure control type “S”:

The device compensator setting-pressure is single and its adjustment is carried out by a mechanical direct acting maximum pressure relief valve.

Working setting pressure is adjustable turning the socket set adjustment screw.

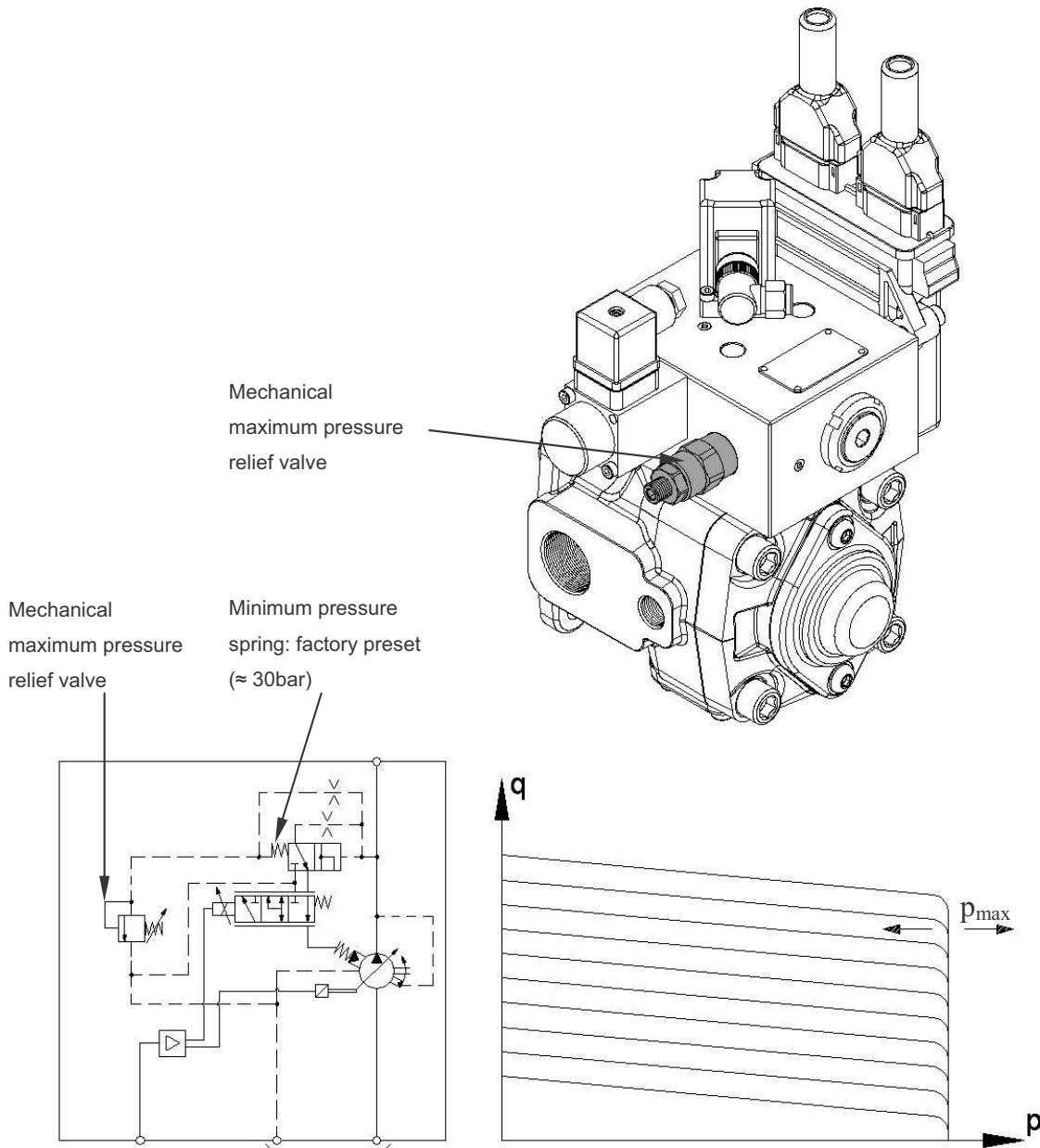

Mechanical direct acting maximum pressure relief valve	
Tightening cartridge torque 40 Nm	
Cartridge hexagonal spanner 22mm	
Locking nut spanner 17mm	
Socket set adjustment screw spanner 5mm	
Rotate clockwise to increase pressure	
<p>NOTE: Pressure peaks are due to the hydraulic system adopted. Pressure peaks exceeding 30% of the maximum operating pressure must be eliminated.</p>	

Pressure control option “ON-OFF” type “P1”:

The device compensator setting-pressure is double (p_{min} and p_{max}) both adjustable utilising “Berarma PHC Software” and carried out by a proportional solenoid valve integrated into the pump (proportional valve utilised in ON-OFF mode).

The two pressure values can be commuted by the pressure control input signal:

- Signal < 5 VDC → setting pressure = p_{min}
- Signal > 5 VDC → setting pressure = p_{max}

Note on cables and connectors (see page 16):

Electronic driver → Pressure relief valve (EVP) included

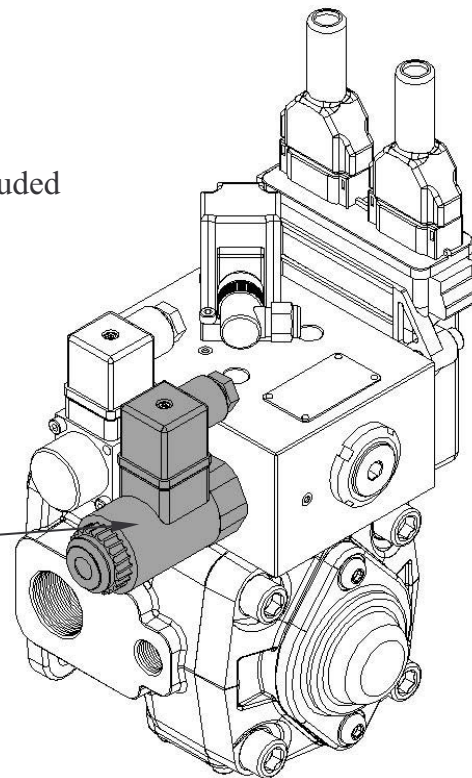

Proportional option ON-OFF maximum pressure relief valve (EVP)

Minimum pressure spring: factory preset (≈ 30 bar)

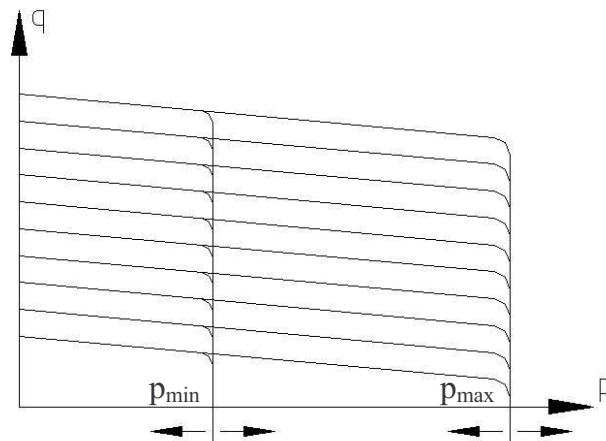
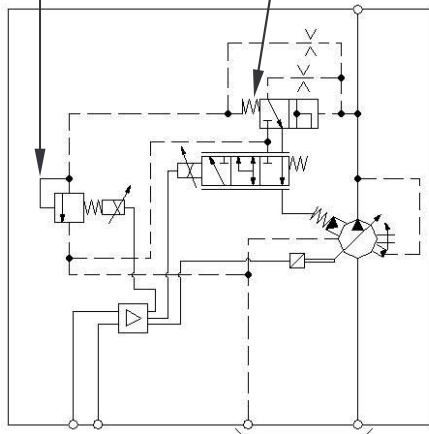

Proportional option ON-OFF maximum pressure relief valve	
Pressure Control Reference Input Signal	0 ÷ 24 VDC
Max solenoid current	0.9 A
Solenoid impedance	14.5 Ω
NOTE: Pressure peaks are due to the hydraulic system adopted. Pressure peaks exceeding 30% of the maximum operating pressure must be eliminated.	

Proportional pressure control option “Open Loop” type “P2”:

The device compensator setting-pressure is regulated by a proportional solenoid valve integrated into the pump. The electronic system, carried out in open loop controls the working pressure of the pump according to the input reference signal.

Note on cables and connectors (see page 16):

Electronic driver → Pressure relief valve (EVP) included

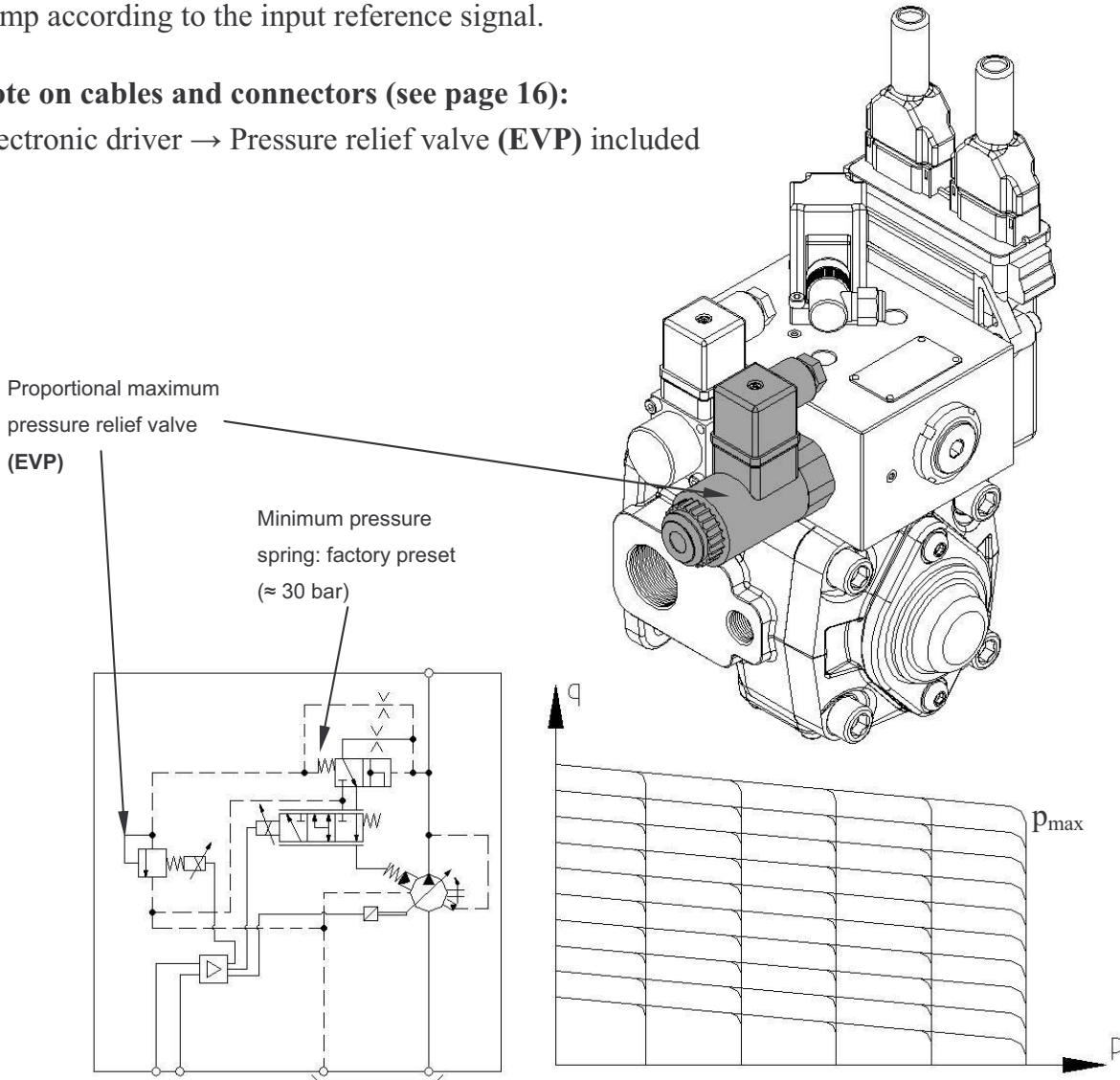

Proportional maximum pressure relief valve		
Pressure Control Reference Input Signal Options		X - 0 ÷ 10 VDC
		Z - 4 ÷ 20 mA
Analog Reference Input Signal Impedance	Voltage signal	>50 kΩ
	Current signal	200 Ω
Max solenoid current		0.9 A
Solenoid impedance		14.5 Ω

Linearity	≤ 2%		approximate values established on Berarma test machine related to 1500 rpm, mineral oil HM according to ISO 6743/4, ISO VG 32 according to ISO 3448, temperature 48°C
Hysteresis	≤ 2%		
Repeatability	≤ 1%		
Response time with stepped reference signal variation	Increasing step	≤ 150 ms	
	Decreasing step	≤ 150 ms	

NOTE: Pressure peaks are due to the hydraulic system adopted.
Pressure peaks exceeding 30% of the maximum operating pressure must be eliminated.

Proportional pressure control option “Closed Loop” type “P3”:

The device compensator setting-pressure is regulated by a proportional solenoid valve integrated into the pump. The electronic system, carried out in closed loop feedback by a pressure transducer, controls the working pressure of the pump according to the input reference signal.

(The pressure transducer, supplied by Berarma only on request, must be mounted by user on the pump outlet pipe.)

Note on cables and connectors (see page 16):

Electronic driver → Pressure relief valve (EVP) included

Electronic driver → Pressure transducer **not included**

Proportional

maximum pressure

relief valve (EVP)

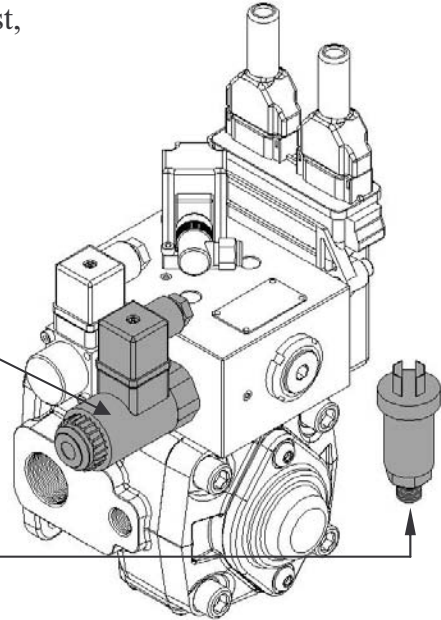
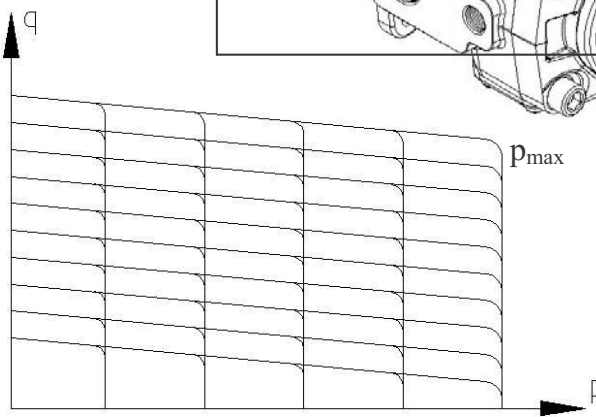
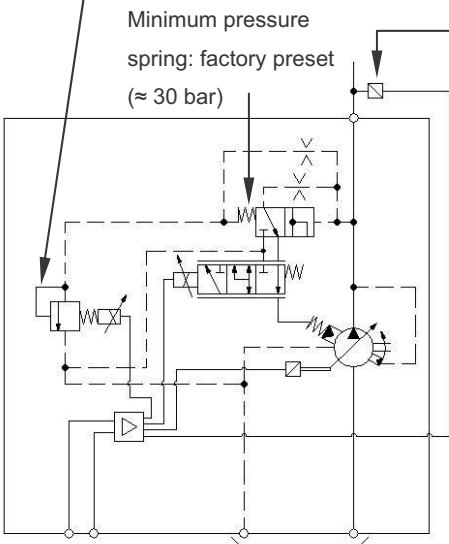

Proportional maximum pressure relief valve

Pressure Control Reference Input Signal Options		X - 0 ÷ 10 VDC
		Z - 4 ÷ 20 mA
Analog Reference Input Signal Impedence	Voltage signal	>50 kΩ
	Current signal	200 Ω
Max solenoid current		0.9 A
Solenoid impedance		14.5 Ω
Pressure Transducer Characteristics	Supply Voltage	24VDC ±10%
	Output Voltage	4 ÷ 20 mA
	Current Consumption Output	< 32 mA

Linearity	≤ 1.5%		approximate values established on Berarma test machine related to 1500 rpm, mineral oil HM according to ISO 6743/4, ISO VG 32 according to ISO 3448, temperature 48°C
Hysteresis	≤ 1.5%		
Repeatability	≤ 0.5%		
Response time with stepped reference signal variation	Increasing step	≤ 150 ms	
	Decreasing step	≤ 150 ms	

NOTE: Pressure peaks are due to the hydraulic system adopted.
Pressure peaks exceeding 30% of the maximum operating pressure must be eliminated.

Power limiter control type “P4”:

The power limiter control is realised combining the closed loop flow-rate and pressure controls (the pressure transducer, supplied by Berarma only on request, must be mounted by user on the pump outlet pipe).

The power limiter control allows the optimum usage of the pump absorbed power.

The operating principle (realised by digital electronic driver) is based on maintaining the flow-rate x pressure product (q x p) practically constant, so that, when working pressure increase, the flow-rate decrease according to a hyperbolic characteristic curve.

Berarma PHC pumps with power limiter control are especially suited for those systems with a working cycle consisting in two operating phases:

- 1° phase characterised by a quick approach and low pressure
- 2° phase characterised by low speed and high pressure (example: forming, drawing, blanking, presses, ...)

In this way, it is possible, using only a pump, to arrange the system where previously two pumps were required.

The characterization of a PHC pump with power limiter control can be done in two modes:

- starting from the power value of the electric motor and from the maximum working pressure, thus obtaining a characteristic curve making it possible for the pump to optimize the usage of the power installed;
- starting from the minimum flow-rate value you would have at the maximum working pressure; in this way the electric motor power and the characteristic curve are determined from defined operating conditions.

From the above data, indicated in the ordering code, Berarma sets the digital electronic driver of the PHC pump, in order to approximate the hyperbolic theoretical curve.

The absorbed pump power can be evaluated by means of the following formula:

$$P[kW] = \frac{p[bar] \times q[l/min]}{600 \times \eta}$$

where :

η = pump total efficiency

($\eta = 0.88$, approximate value)

(P [hp] = P [kW] / 0.75)

Note on cables and connectors (see page 16):

Electronic driver → Pressure relief valve (EVP) included

Electronic driver → Pressure transducer **not included**

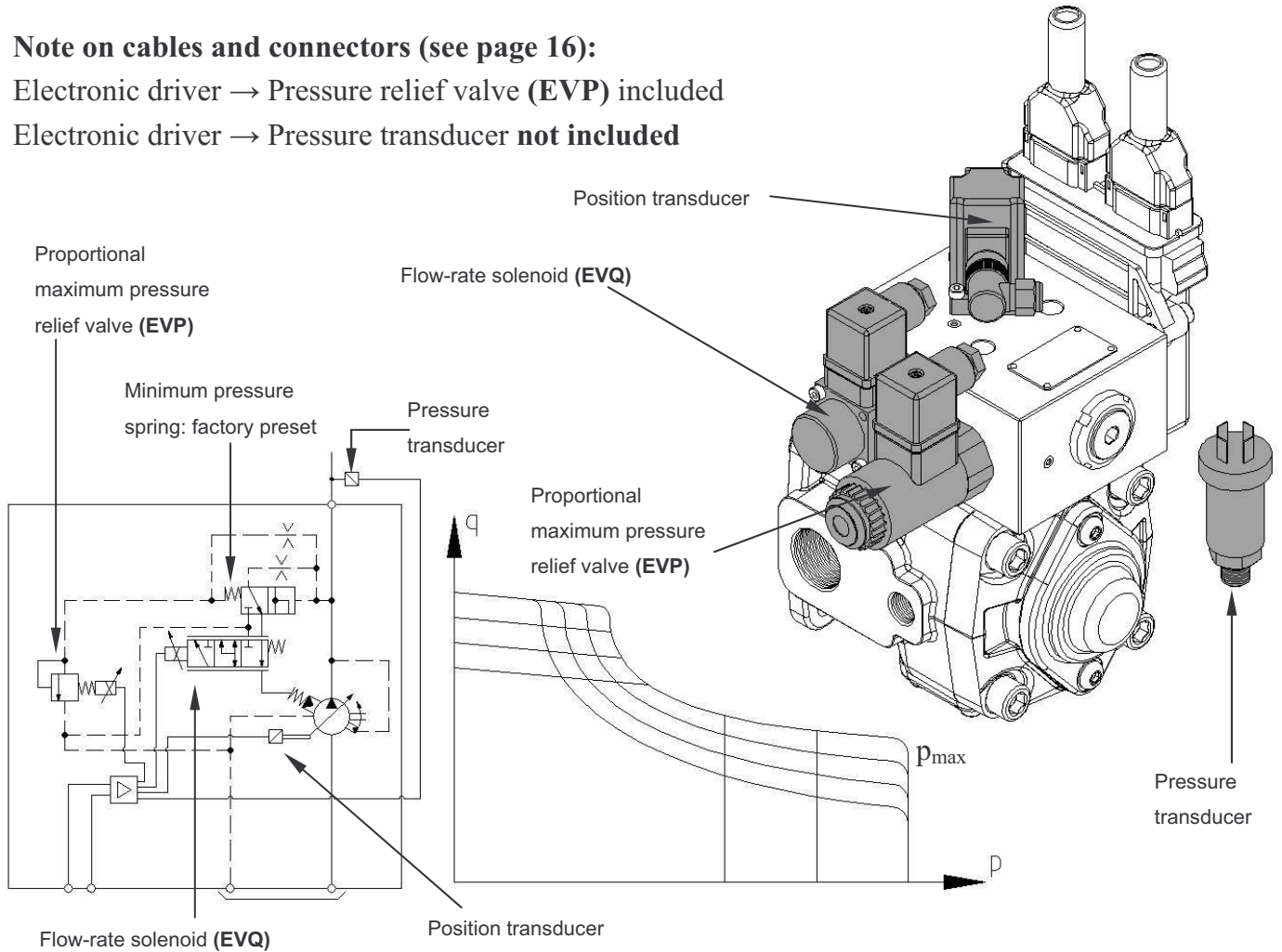

Power limiter control			
Flow-rate	Control Reference Input Signal		Power Limiter Control does not required the connection of the flow-rate reference signal cable
	Max solenoid current		0.68 A
	Solenoid impedance		24.6 Ω
	Position Transducer Characteristics	Power Supply	24VDC ±10%
		Current Consumption	< 50mA
	Output Voltage	6 ÷ 9 VDC	
Pressure	Control Reference Input Signal Options		X - 0 ÷ 10 VDC
			Z - 4 ÷ 20 mA
	Analog Reference Input Signal Impedance	Voltage signal	>50 kΩ
		Current signal	200 Ω
	Max solenoid current		0.9 A
	Solenoid impedance		14.5 Ω
	Pressure Transducer Characteristics	Supply Voltage	24VDC ±10%
Output Voltage		4 ÷ 20 mA	
Current Consumption Output		< 32 mA	

NOTE: Pressure peaks are due to the hydraulic system adopted.
Pressure peaks exceeding 30% of the maximum operating pressure must be eliminated.

In order to optimize the application performances of PHC pumps, Berarma, on request, can supply the software “**Berarma PHC Software**”. Through “Berarma PHC Software” it is easy to carry out all settings and adjustments of the electronic driver of PHC Pump.

Features and characteristics :

- CD-ROM media
- RS232 serial communication interface (cable RS232 supplied only on request)
- Setting of type of flow-rate and/or pressure and/or power limiter control
- Setting of type of reference signals of flow-rate and pressure control
- Setting of flow-rate and pressure working range
- Setting of the pump power consumption
- Real time monitor of the main parameters
- Faults management
- Possibility to save and recovery PHC pump settings

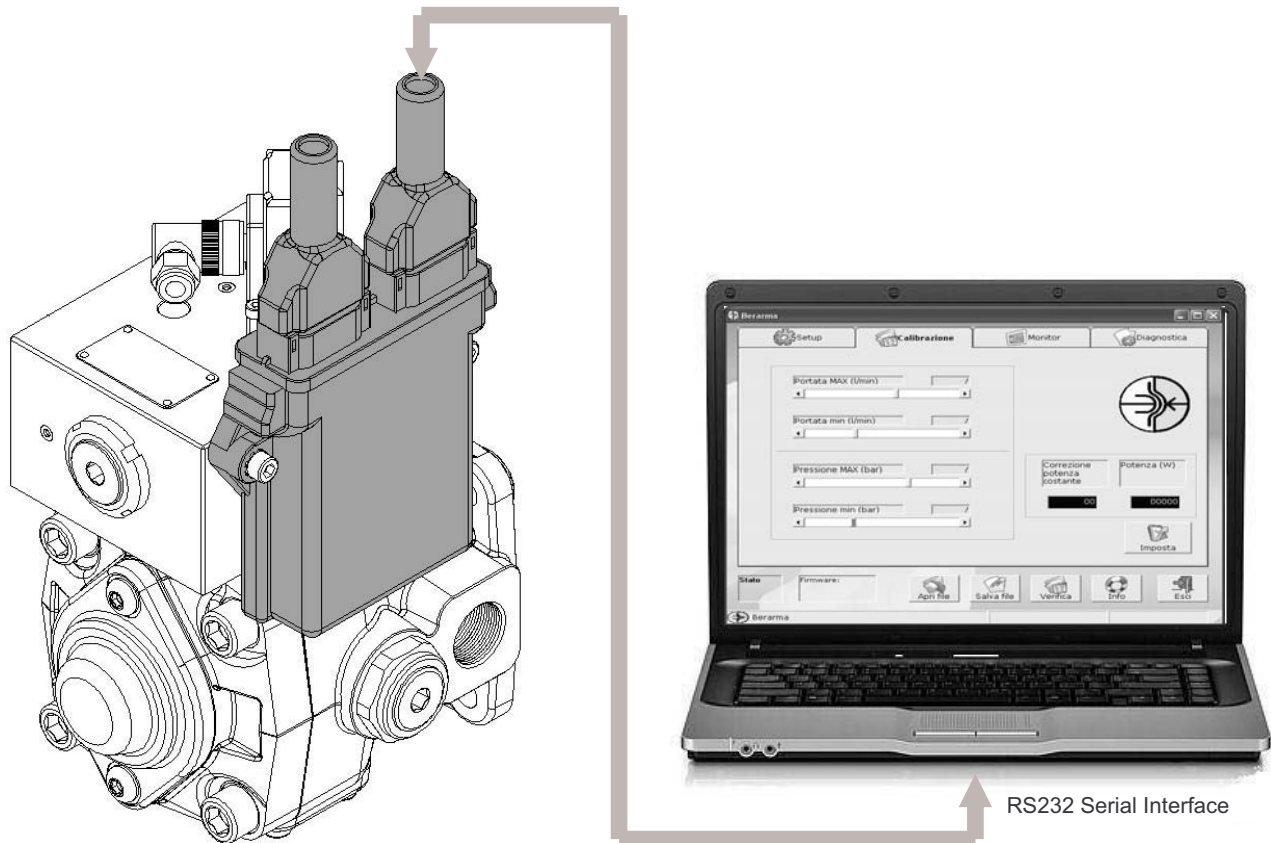

All Berarma PHC pumps have been carefully controlled during manufacture and subjected to stringent testing cycles before shipment. During these cycles, Berarma has configured the digital electronic driver of PHC pump, setting the different parameters on standard values or on specific values requested by user. Then, for the right functionality of PHC pump it **is not necessary to modify the setting of the digital electronic driver realised by Berarma**. Finally for the operating of PHC pump it is not requested the connection between the digital electronic driver and personal computer. For further informations regarding “Berarma PHC software”, please consult the relevant instructions leaflet or contact Berarma Sale-Technical Service.

DEUTSCH INDUSTRIAL DTM06-12SB BLACK CONNECTOR

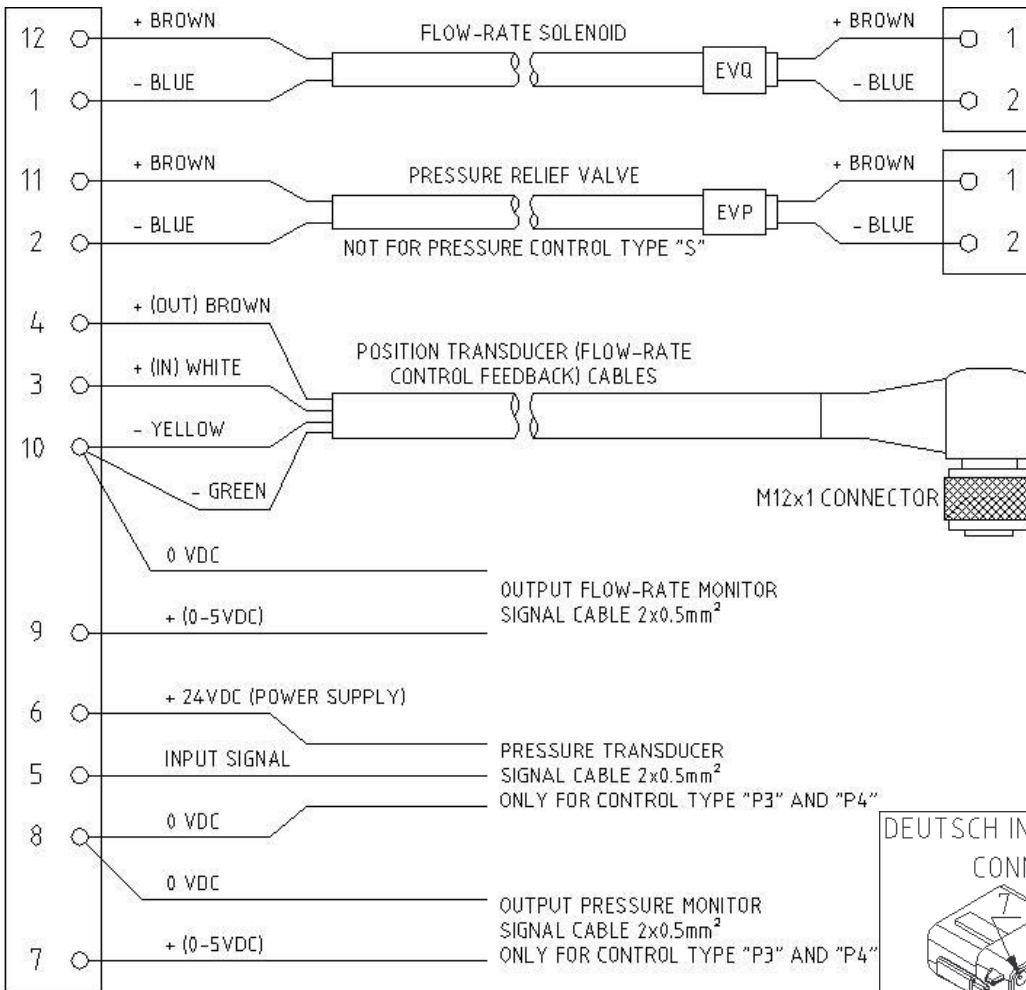

DIN 43650 CONNECTOR (EN 175301-803 TYPE A)

DIN 43650 CONNECTOR (EN 175301-803 TYPE A)

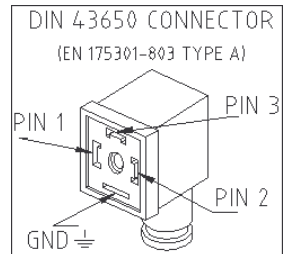

DEUTSCH INDUSTRIAL DTM06-12S GREY CONNECTOR

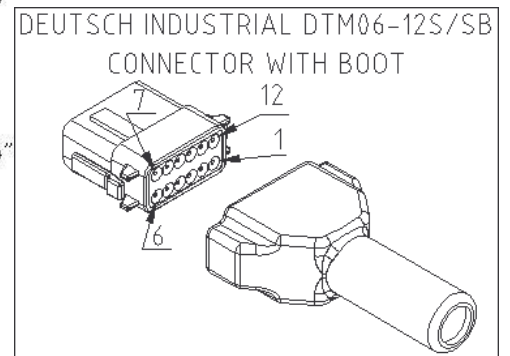
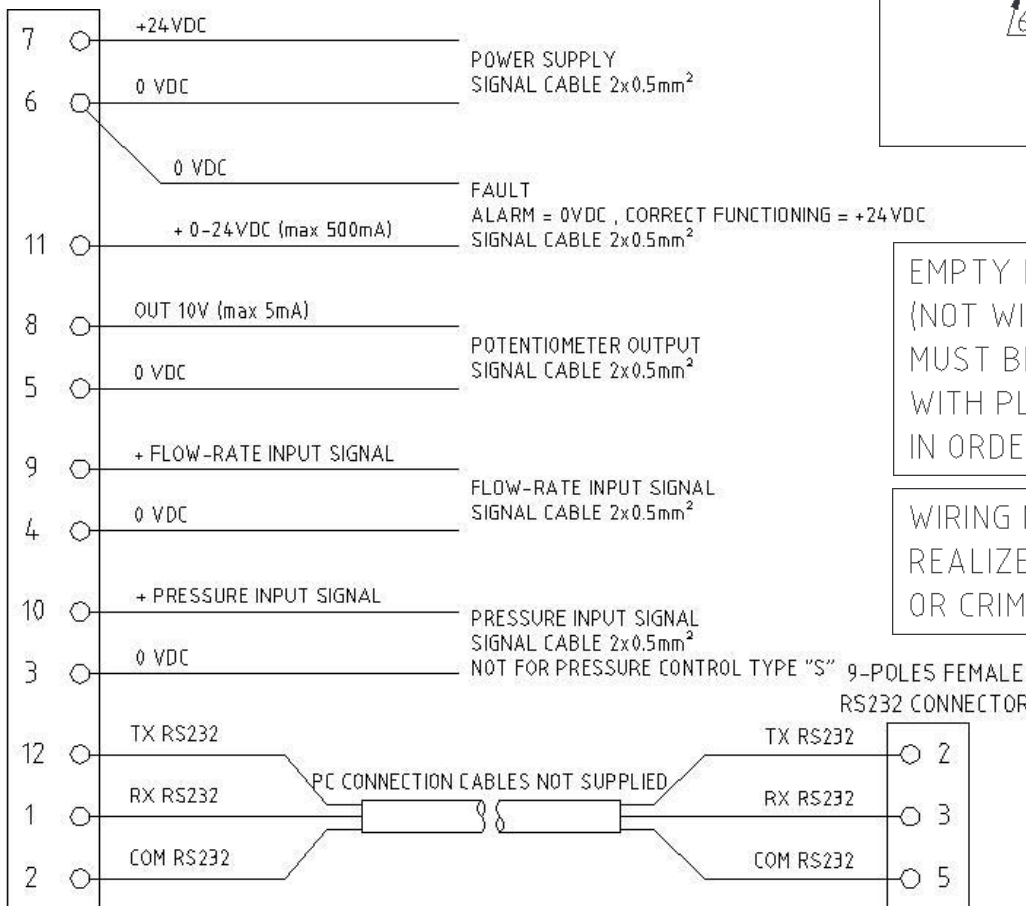

EMPTY POLES (NOT WIRED) MUST BE PLUGGED WITH PLASTIC PINS IN ORDER TO KEEP BOX SEAL

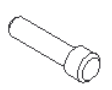

WIRING MUST BE REALIZED WELDING OR CRIMPING THE PINS

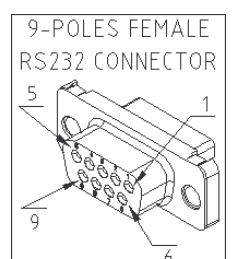

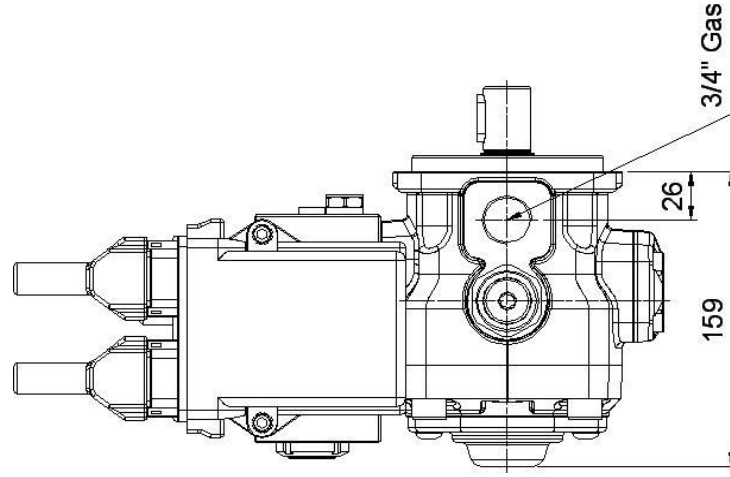
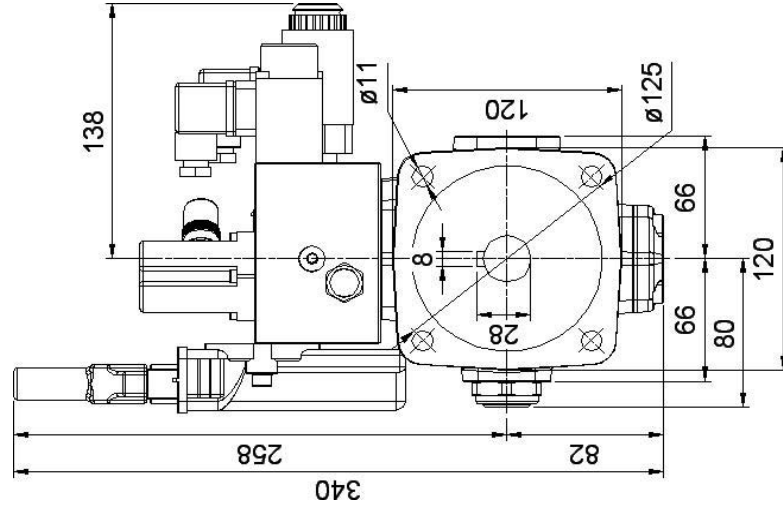
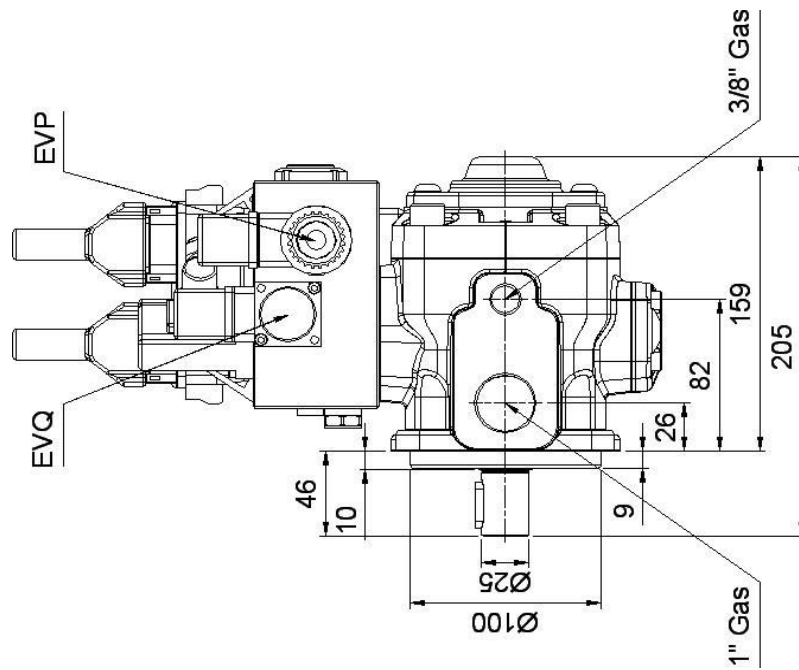

02 PHC 1 25 FHRM P2

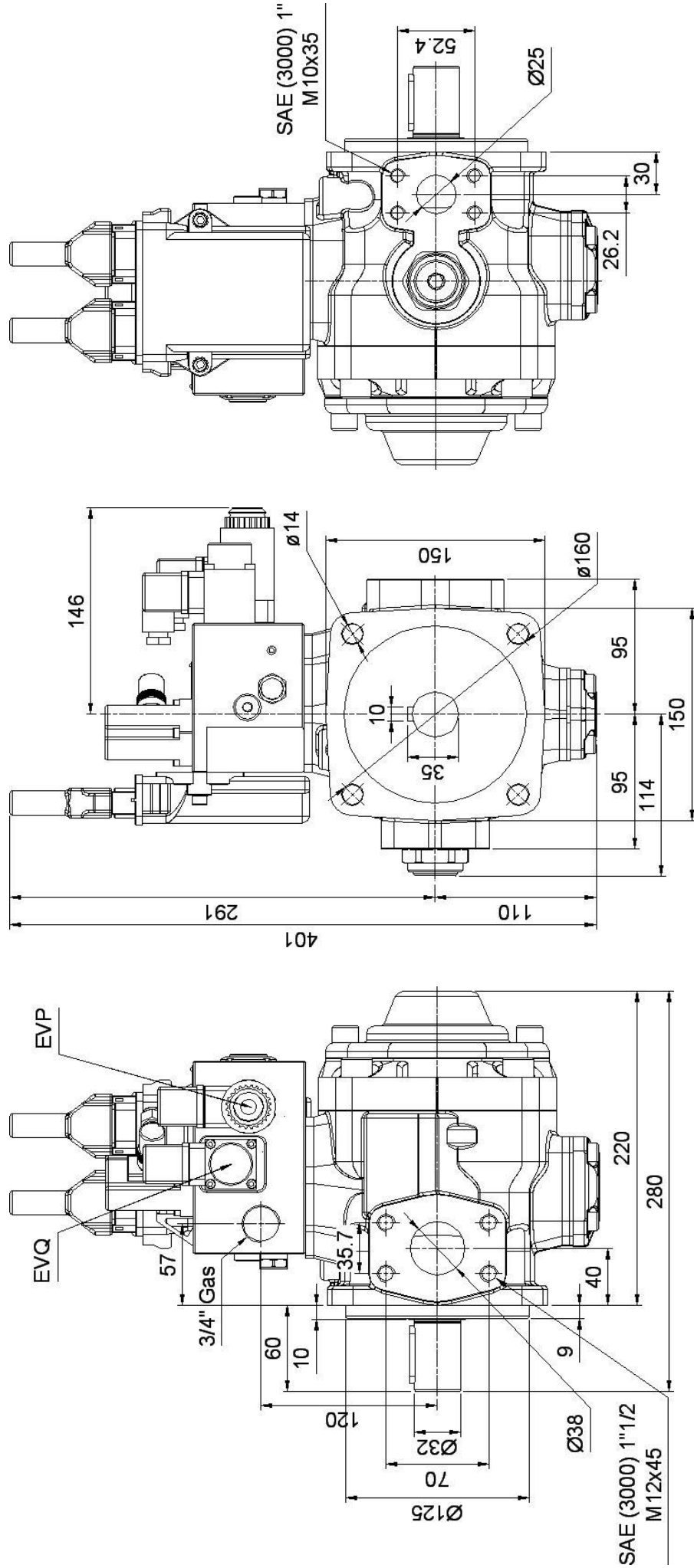

NOTE: Cables dimensions are not included in the drawing above

02 PHC 2 50 FHRM P2



NOTE: Cables dimensions are not included in the drawing above

02 PHC 3 100 FHRM P2

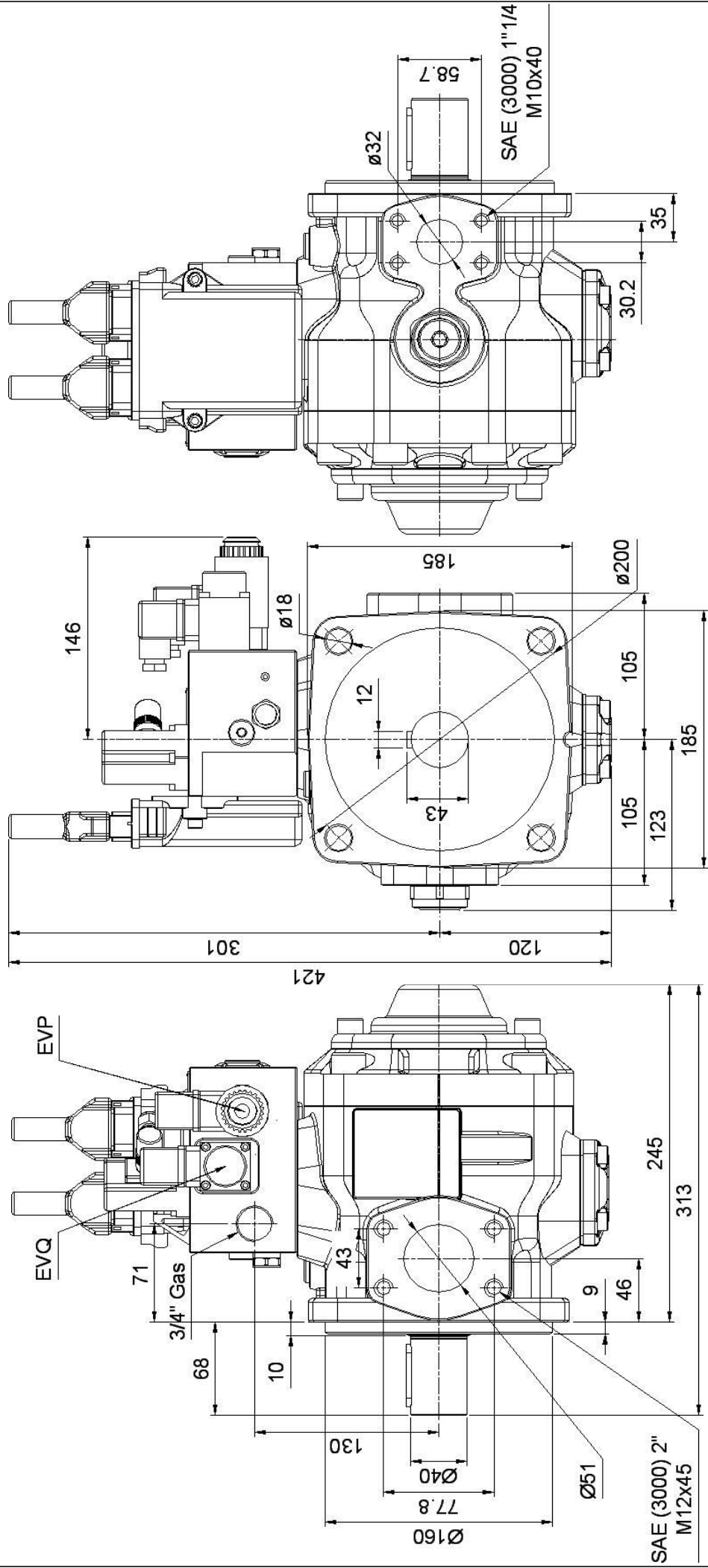

NOTE: Cables dimensions are not included in the drawing above

All size of PHC Pumps must be mounted with the **shaft HORIZONTAL** and the **compensator device upward**.

PHC pumps can not be installed inside the reservoir.

When the pump is installed over the reservoir fluid level, it is recommended to pay attention to the inlet pressure.

Cleanliness is essential when assembling!

TRANSMISSION

Motor - pump coupling must be made with self-aligning coupling with convex teeth and with cam in polyamide material.

When assembling make sure that:

- **the distance between the two half-couplings falls imperatively within the value specified in the figure;**
- **the pump shaft and the motor shaft are accurately aligned: coaxial within 0.05 mm, angular displacement within 0.2°;**
- **do not strictly operate radial or axial load on the pump shaft.**

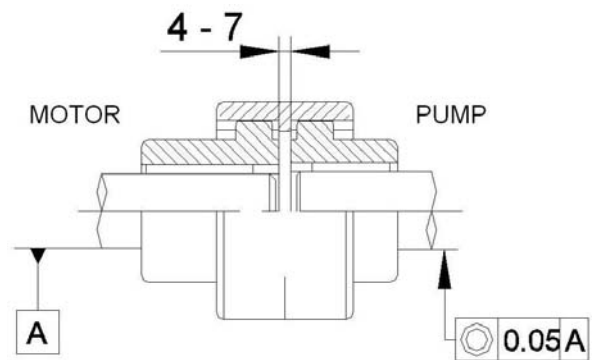

Others type of motor – pump couplings are not permitted.

FLUID RESERVOIR

The fluid reservoir must be suitably sized in order to exchange the thermal power generated to the system components and to have a low re-cycle speed (approximately oil reservoir capacity 4 times the pump flow per minute). In the systems where the pump runs for a long time in zero flow setting condition, it is recommended to install a heat exchanger on the drain line (pay attention to the pressure on the drain port).

Maximum operating temperature must not exceed 60°C in any circumstances.

To ensure maximum pump working life, inlet fluid temperature must never be above 50°C.

PIPE WORK

Suction pipe. The suction pipe should be as short as possible, with a minimum numbers of bends and without inside section changes. The minimum section of the inlet pipe must be equal to the section of the thread inlet port of the pump. The pipe end inside the reservoir should be cut at 45°, should have a minimum distance from the reservoir bottom not less than 50 mm, and should be always guaranteed a minimum height of suction of 100 mm. The minimum section of the pipe must be equal to the section of the thread inlet port of the pump. **The suction pipe should be completely airtight.**

Drain pipe. The drain pipe must always be independent of other return lines, connected directly to the reservoir and extended sufficiently inside the reservoir as to be below the minimum fluid level in order to avoid generating foam and to prevent emptying when the pump is not running. Moreover, the case/compensator drain connection must be at the highest possible position, always to prevent fluid emptying from the pump and must be free of restrictions. **All return and drain pipes should be as far as possible from the suction pipe to prevent hot fluid being circulated.**

Pressure line. Ensure that the pressure line is of sufficient strength. It is recommended to install on pump pressure line a non-return valve (ex.: **“Berarma non-return valve type NRV” with SAE flange, 3000 series for SIZE 2, SIZE 3 pumps**) and an automatic air bleed valve, for trouble free operation.

START UP

Ensure that any valves, throttles in the suction and pressure pipes are fully open and all protective caps are removed. Fill the pump through the case drain port and replace the drain pipework. Check that the reservoir is full of fluid. **Ensure that the pump shaft can be rotated manually without any resistance.**

Check that the motor direction rotation coincides with pump direction rotation: right-hand rotation (clockwise) viewed from shaft end of the pump.

Start the motor (in jogging mode), allowing free circulation of fluid to reservoir, in order to aid the primer of the pump.

The pump should prime within 5 seconds. If it does not do so, switch off and investigate the cause. The pump should not run empty.

During the **FIRST INSTALLATION**, the pump must run in maximum flow condition (P connected to T and **with flow-rate reference signal setted to the maximum value**), with the fluid flowing directly into the reservoir, without pressure for several minutes (SIZE 1: 3÷5 minutes; SIZE 2 – SIZE 3: 7÷10 minutes). Care should be taken to **eliminate all the air from the system** during this process.

Subsequent starting in zero flow setting condition are admissible only with pressure not exceeding 30 bar, and on condition that the system and pump be completely filled up with fluid.

If the flow-rate reference signal is setted less 50% than the maximum flow-rate value, starting are admissible only on condition that the system and the pump be completely filled up with fluid.

During the starting operation, both the first and the followings, it is necessary that the pump (environment) and the fluid temperature don't differ by more than 20°C. If that is the case, the pump may be switched on only in short intervals of approximately 1÷2 seconds (start/stop mode) without pressure, until the temperatures are balanced.

PHC pump: assembling drawing		
Ref.	Description	Q.ty
1	Socket head cap screw M6x25	2
2	Serrated lock washer $\varnothing_1 6.4\text{mm}$, $\varnothing_e 11\text{mm}$, thick 0.7mm	2
3	Connector Deutsch Industrial DTM06-12SB, colour black (and relative boot)	1
4	Connector Deutsch Industrial DTM06-12S, colour grey (and relative boot)	1
5	Position transducer	1
6	Flow-rate solenoid (EVQ)	1
7	Pressure relief valve (EVP)	1
8	Digital electronic driver	1
9	Pressure transducer (only for "P3" and "P4" control)	1

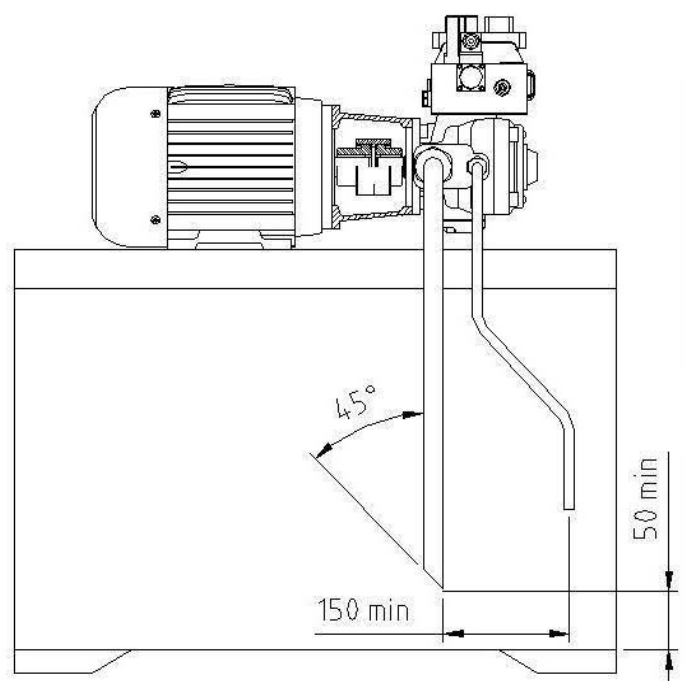
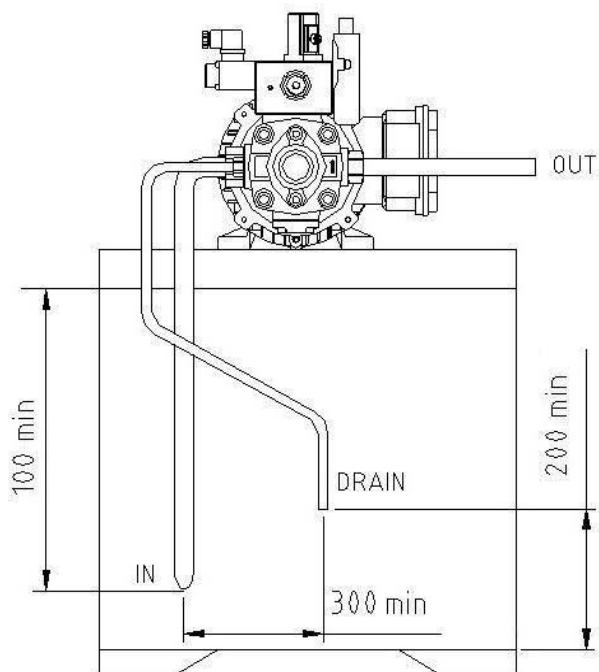
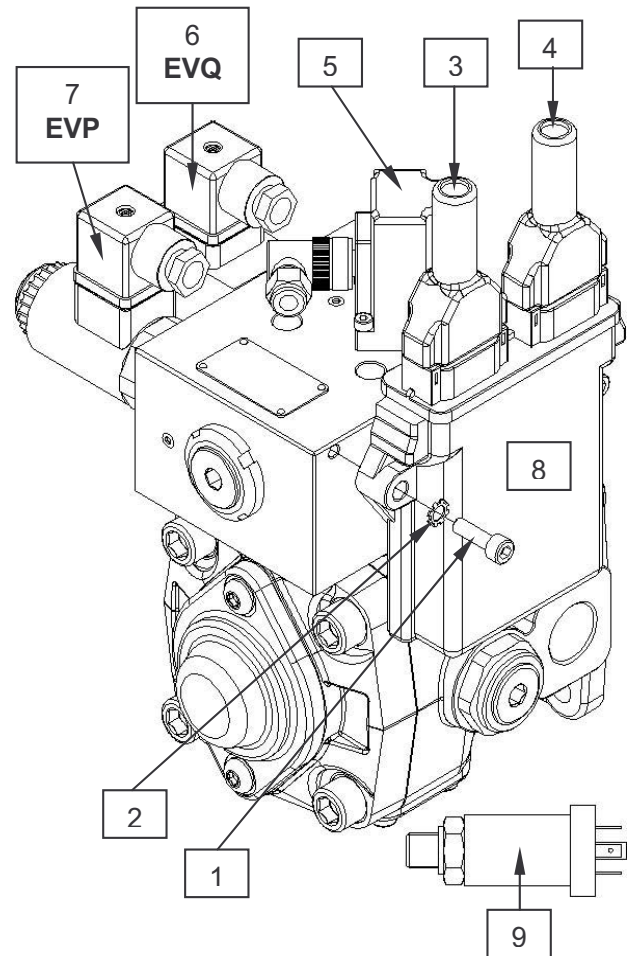



oleodinamica

Via G. Parini, 9 - 40033 Casalecchio di Reno (BO) Italy
Tel.: +39 051 577 182 ra - Fax +39 051 578 489
www.berarma.it - e-mail: info@berarma.it