



**"G" SERIES SHOCKLESS TYPE
SOLENOID OPERATED DIRECTIONAL VALVES
G-DSG-01/03 (1/8, 3/8)**

**"G" SERIES SHOCKLESS TYPE
SOLENOID CONTROLLED PILOT OPERATED
DIRECTIONAL VALVES
G-DSHG-04/06 (1/2, 3/4)
Sub-plate Mounting**

**DIRECTIONAL
CONTROLS**

Up to 25 MPa (3630 PSI), 250 L/min (66.1 U.S.GPM)

The G-Series Solenoid Operated Directional Valves incorporate electronic circuits to enable adjustment of the spool shifting time. As the shifting time of the G-Series valves can be adjusted, it can be set at an optimal level to minimise shocks to the machine.



G-DSG-01



G-DSHG-04



1 Reduces oil hammering during spool changeover.

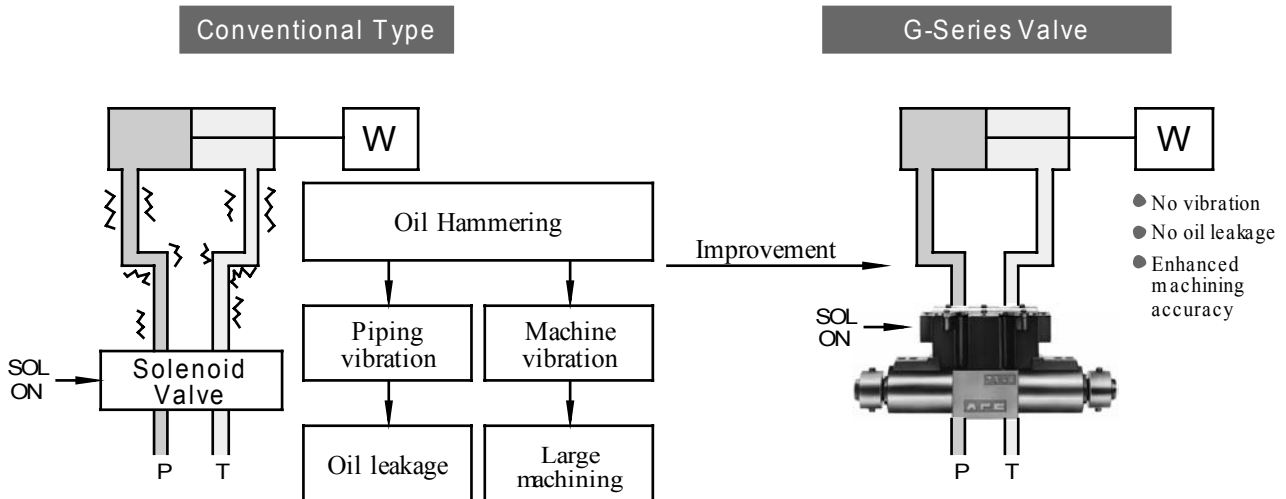

2 Reduces shock caused by acceleration and deceleration

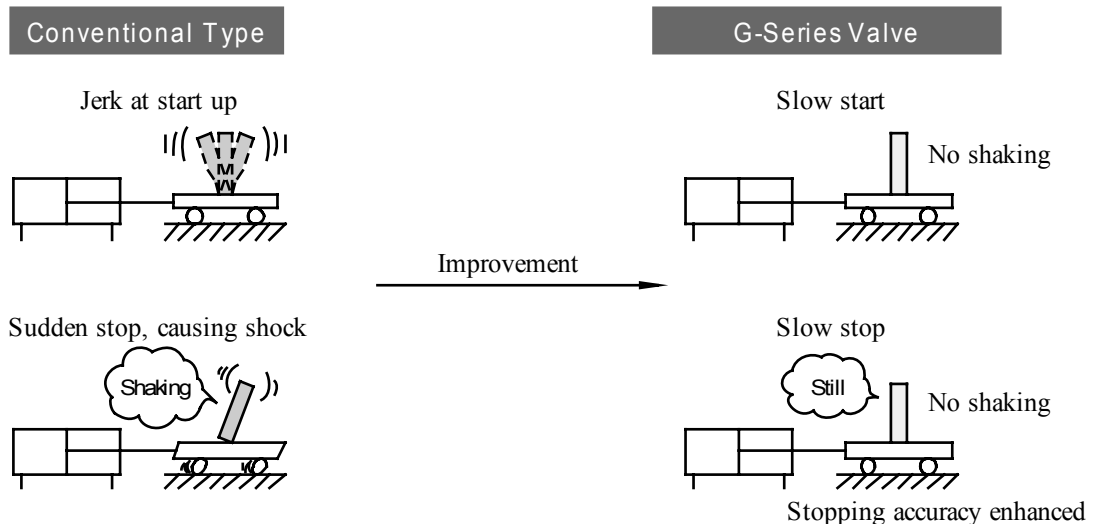

System Diagram (Example of sink type wiring)

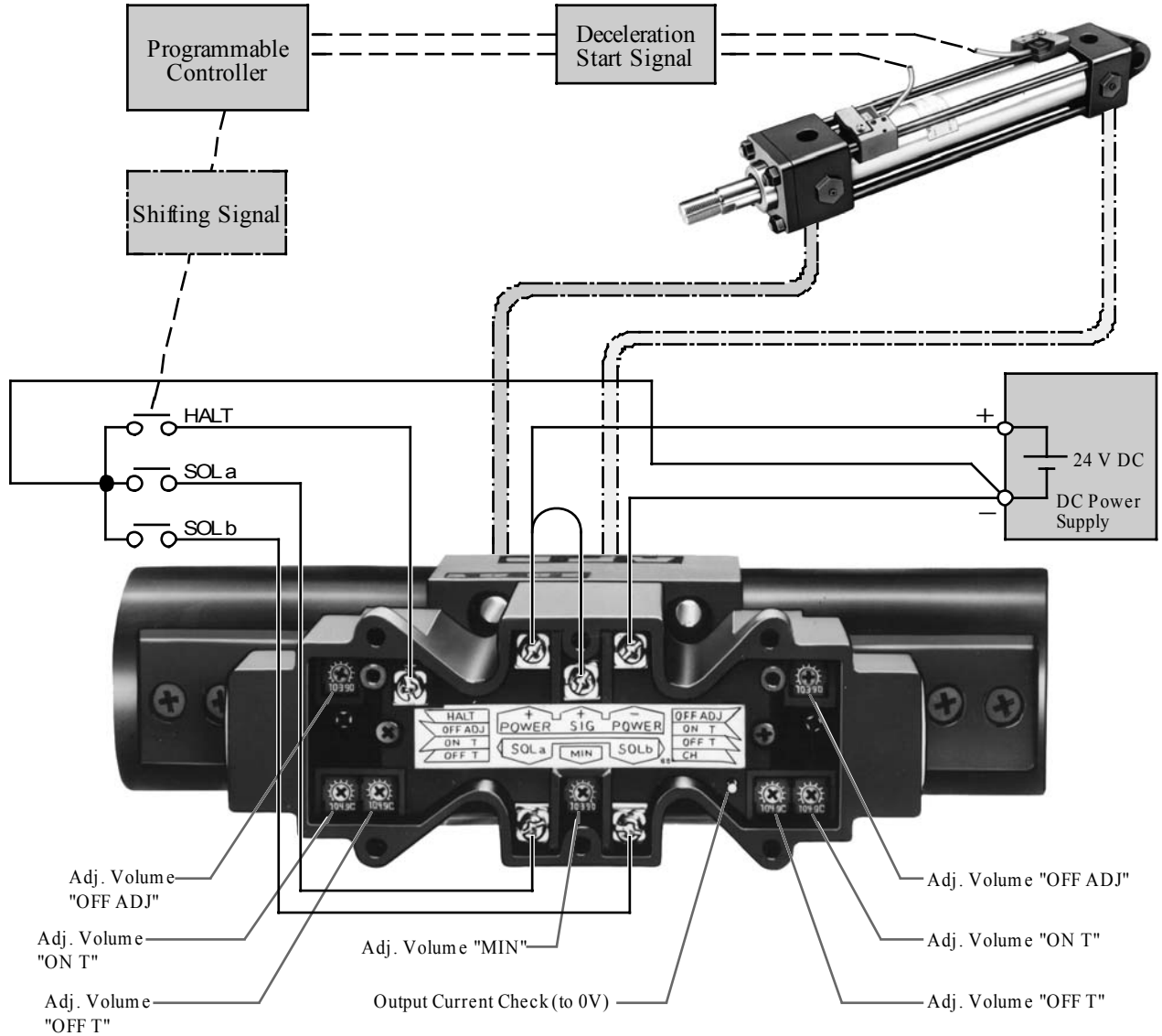

Relationships between SOL signals and flow patterns

Without HALT functions

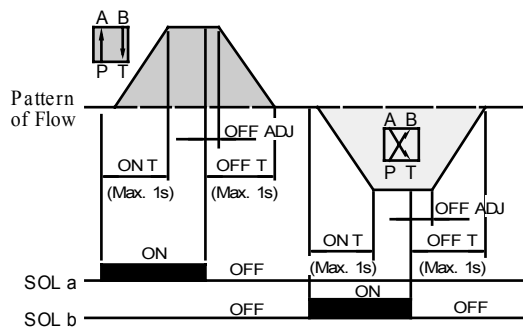

With HALT functions

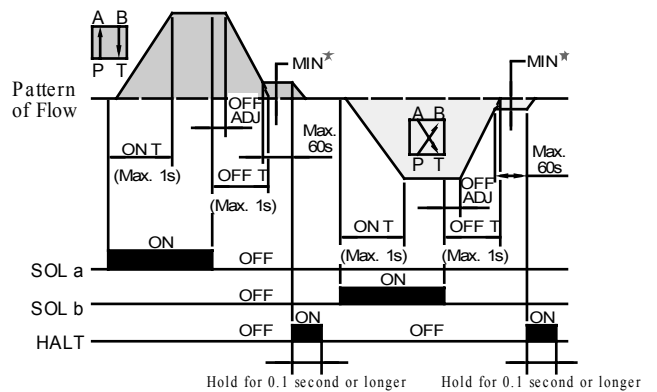

★ The minimum adjustment volume is common for SOL a and b, and it is not possible to set a different volume for each SOL a and b individually. If the HALT functions are not used, set the minimum adjustment volume to zero.

Hydraulic Fluids

Fluid Types

Any type of hydraulic fluids listed in the table below can be used.

Petroleum base oils	Use fluids equivalent to ISO VG 32 or VG 46.
Synthetic fluids	Use phosphate ester or polyol ester fluid. When phosphate ester fluid is used, prefix "F-" to the model number because the special seals (fluororubber) are required to be used.
Water containing fluids	Use water-glycol fluids or W/O emulsion type fluids.

Note: For use with hydraulic fluids other than those listed above, please consult your Yuken representatives in advance.

Recommended Viscosity and Oil Temperatures

Viscosity ranging between 15 - 200 mm²/s (77 - 927 SSU).

Oil temperatures between -15/+60°C (5 - 140°F).

Use hydraulic fluids which satisfy the recommended viscosity and oil temperatures given above.

Control of Contamination

Due caution must be paid to maintaining control over contamination of the hydraulic fluids which may otherwise lead to breakdowns and shorten the life of the valves. Please maintain the degree of contamination within NAS 1638-Grade 12. Use 25 μm or finer line filter.

Instructions

Adjustment of maximum flow rate

The G-Series Solenoid Operated Directional Valves cannot be adjusted for maximum flow rates.

To adjust maximum flow rates, use flow control valves. In G-series solenoid controlled pilot operated directional valves (G-DSHG-04/06), the maximum flow rate can be adjusted by use of the valve with stroke adjustment screw of optional extra.

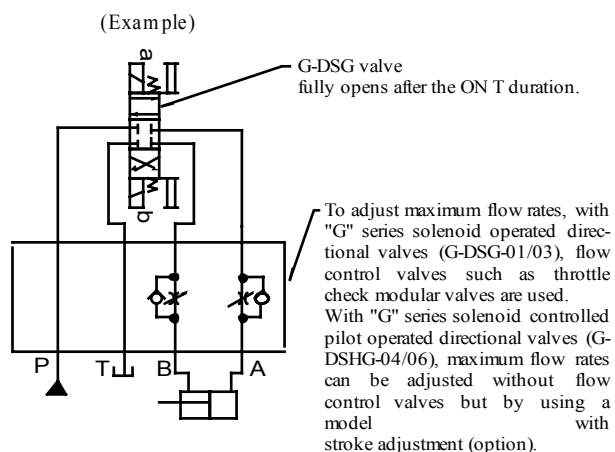

How to use HALT functions

The HALT functions are used to drive the actuator at a low speed to the stop position while keeping a slight flow after OFF T.

A flow rate (min. flow rate) during a low-speed operation can be set with the minimum adjusting volume (The minimum adjusting volume is common for SOL a and b. Individual setting is not possible for SOL a and b.) When HALT signal is on, the min. flow rate becomes zero and the actuator stops. Here, take care to keep the HALT signal on for longer than 0.1 second. The min. flow rate gets to "0" after about 60 seconds following the OFF T. If the HALT functions are not used, set the minimum adjusting volume to zero.

The HALT functions are not applicable to the spool function "2B7".

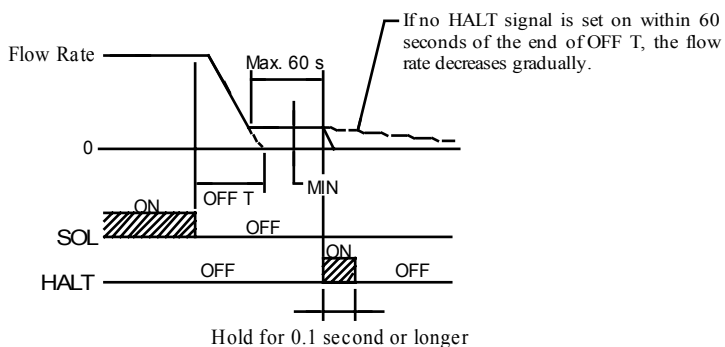

● **Precautions in case pilot controlled check valves are used**

In a hydraulic circuit where a pilot controlled check valve is used, there is a possibility that the knocking will arise on the pilot controlled check valve during deceleration depending on the largeness of load inertia, the state of piping and the length of "Off T" time etc.

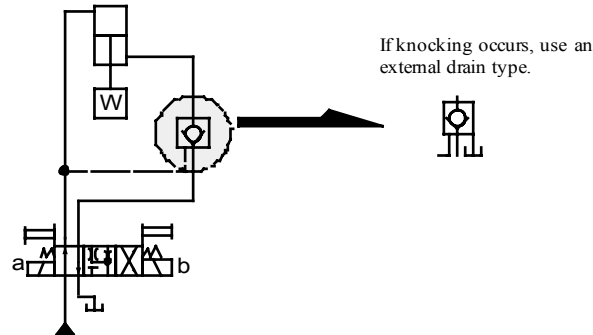

● **Air bleeding**

To achieve a stable "shockless" effect, discharge air by loosening the air vent and fill the iron core of the solenoid with fluid.

Each solenoid has two air vents, loosen either one. After air discharge, be sure to retighten the air vent.

● **Tank piping (for G-DSG-01/03)**

Do not connect the tank line to any line subject to a surge pressure. To obtain a stable "shockless" effect, take care not to allow the fluid in the iron core of the solenoid to flow out. To ensure this, it is best to use check valves having a cracking pressure of about 0.035 MPa (5 PSI).

● **Manual shifting**

If no shifting signal voltage is given to the valve in an initial operation or an electrical fault, temporary valve shifting can be carried out by pushing the manual operation push pin. In addition, note that if the back pressure of the tank line increases, manual operation of the push pin gets harder.

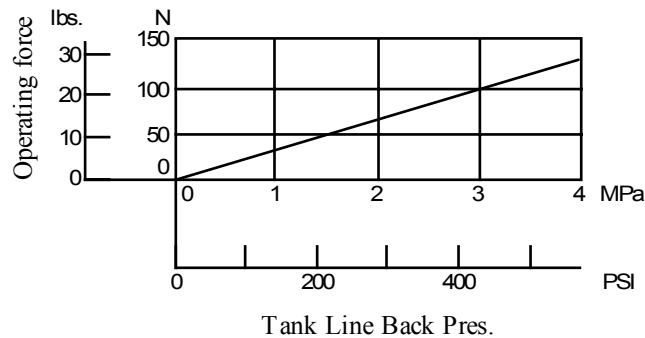

● **Drain piping (for G-DSHG-04/06)**

Allowable back pressure is 3 MPa (440 PSI). Take care to eliminate pressure fluctuation and keep the pressure as low as possible. To ensure this, it is best to use check valves having a cracking pressure of about 0.035 MPa (5 PSI). Be sure to hold the end of the pipe in the fluid.

● **Mounting Posture**

There are no restrictions on mounting posture for these valves.

Specifications

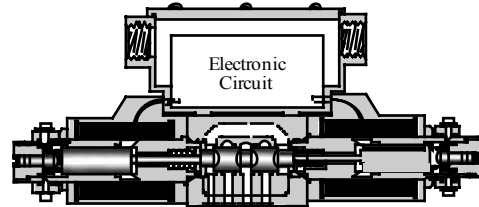

■ Specifications

Descriptions		Model Numbers	G-DSG-01-***-*/50/5090	G-DSG-03-***-*/50/5090
Max. Flow ^{★1}	L/min (U.S.GPM)		10 (2.6), 20 (5.3), 30 (7.9), 40 (10.6)	40 (10.6), 60 (15.9), 80 (21.1)
Max. Operating Pres. ^{★2}	MPa (PSI)		25 (3630)	25 (3630)
Max. T-Line Back Pres.	MPa (PSI)		16 (2320)	16 (2320)
Electric Power Supply	Voltage	24 V DC (21 - 28 V DC Included Ripple): Use a stable power supply		
	Input Power at 24V		36 W	36 W
Shifting signal, low speed operation halt signal (can be used in com m on with electric power supply).	Voltage	5 - 48 V DC (Use a stable power supply)		
	Current	Constant at 10 m A (A constant-current circuit is used)		
	Input interface	Sink Type, Source Type		
Shifting time range (for ON and OFF)			0.1 - 1 s	0.3 - 1 s
Low speed operation flow rate (min. flow rate) range (for SOL a and b) L/min (U.S.GPM)			0.5 - 5 (.13 - 1.3)	1 - 10 (.26 - 2.6)
Low speed operation flow rate (min. flow rate) hold time			Max. 60 s (After 60 seconds, the flow rate decreases gradually.)	
Ambient Temperature			0 - 50 °C (32 - 122 °F) with circulated air	
Approx. Mass	Single Solenoid		2.1 kg (4.6 lbs.)	5.3 kg (11.7 lbs.)
	Double Solenoid		3.0 kg (6.6 lbs.)	7.5 kg (16.5 lbs.)

★ 1. The maximum flow rates may vary according to the operating pressure. Refer to Maximum Flow Rates Characteristics on pages 7 and 8 for
★ 2. details.

At pressures more than 21 MPa (3050 PSI), the "shockless effect" is slightly less if compared it with that at 16 MPa (2320 PSI).



Model Number Designation

G-DSG	-01	-10	-2B7	-S	-50	*	-L
Series Number	Valve Size	Metred Flow Capacity	Spool Type	Input Interface	Design Number	Design Standards	Models with Alternate Offset Solenoid
G-DSG : G Series Shockless Type Solenoid Operated Directional Valve, Sub-plate Mounting	01	None: 40 L/m in 10 : 10 L/m in 20 : 20 L/m in		None: Sink Type (Standard) S: Source Type	50	Refer to ★	L Applicable only for 2B7 (Omit if not required)
		None: 30 L/m in 10 : 10 L/m in 20 : 20 L/m in					
	03	None: 80 L/m in 40 : 40 L/m in 60 : 60 L/m in			50		
		None: 60 L/m in 40 : 40 L/m in					

★ Design Standards: None Japanese Standard "JIS" and European Design Standard
 90 N. American Design Standard

Sub-plate

Valve Model Numbers	Japanese Standard "JIS"		European Design Standard		N. American Design Standard		Approx. Mass kg (lbs.)
	Sub-plate Model Numbers	Thread Size	Sub-plate Model Numbers	Thread Size	Sub-plate Model Numbers	Thread Size	
G-DSG-01	DSGM-01-30	Rc 1/8	DSGM-01-3080	1/8 BSP.F	DSGM-01-3090	1/8 NPT	0.8 (1.8)
	DSGM-01X-30	Rc 1/4	DSGM-01X-3080	1/4 BSP.F	DSGM-01X-3090	1/4 NPT	0.8 (1.8)
	DSGM-01Y-30	Rc 3/8	—	—	DSGM-01Y-3090	3/8 NPT	0.8 (1.8)
G-DSG-03	DSGM-03-40	Rc 3/8	DSGM-03-2180	3/8 BSP.F	DSGM-03-2190	3/8 NPT	3.0 (6.6)
	DSGM-03X-40	Rc 1/2	DSGM-03X-2180	1/2 BSP.F	DSGM-03X-2190	1/2 NPT	3.0 (6.6)
	DSGM-03Y-40	Rc 3/4	DSGM-03Y-2180	3/4 BSP.F	DSGM-03Y-2190	3/4 NPT	4.7 (10.4)

● Sub-plates are available. Specify the sub-plate model number from the table above. When sub-plates are not used, the mounting surface should have a good machined finish.

Attachment (Mtg. Bolt)

Four socket head cap screws in the table below are included.

Model Numbers	Socket Head Cap Screw (4 pcs.)		
	Japanese Standard "JIS" & European Design Standard	N. American Design Standard	Tightening Torque
G-DSG-01	M5 × 45 Lg.	No.10-24 UNC × 1-3/4 Lg.	5-7 Nm (44-62 in. lbs.)
G-DSG-03	M6 × 35 Lg.	1/4-20 UNC × 1-1/2 Lg.	12-15 Nm (106-133 in. lbs.)

Performance Characteristics

Hydraulic Fluid: Viscosity 30 mm²/s (141 SSU), Specific Gravity 0.850

Maximum Flow Rate

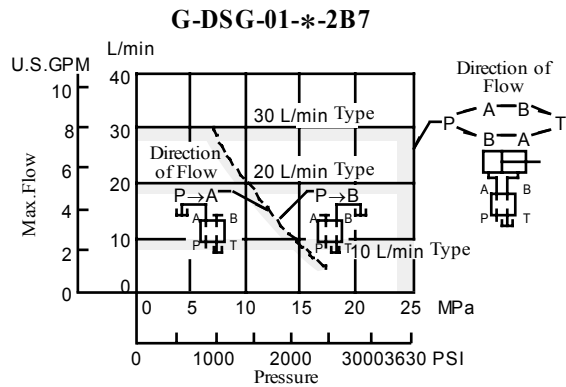
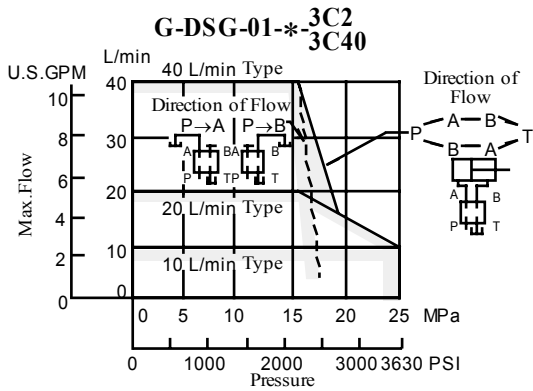

Pressure Drop

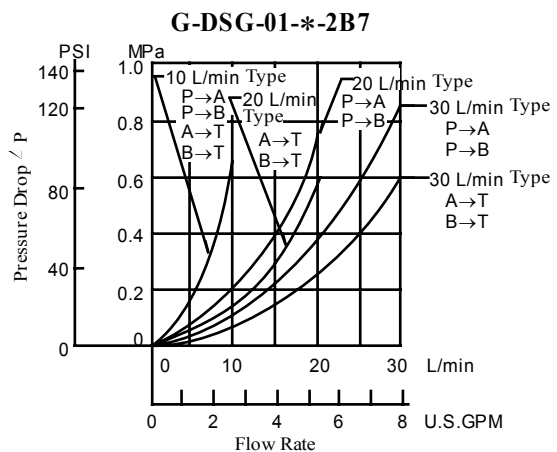
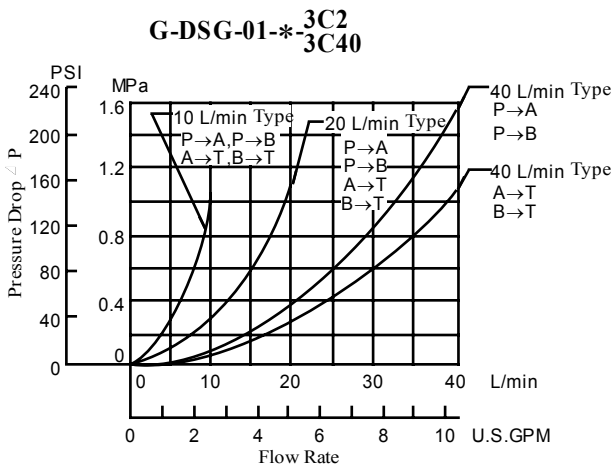

- For any other viscosity, multiply the factors in the table right.
- For any other specific gravity (G'), the pressure drop (ΔP) may be obtained from the formula below.

$$\Delta P' = \Delta P (G'/0.850)$$

Viscosity	mm ² /s	15	20	30	40	50	60	70	80	90	100
	SSU		77	98	141	186	232	278	324	371	417
Factor		0.84	0.91	1.00	1.07	1.14	1.19	1.24	1.28	1.32	1.35

Shifting Characteristics

Supply Pressure : 16 MPa (2320 PSI)
Flow Rate : 30 L/min (7.9 U.S.GPM)

3C2, 3C40

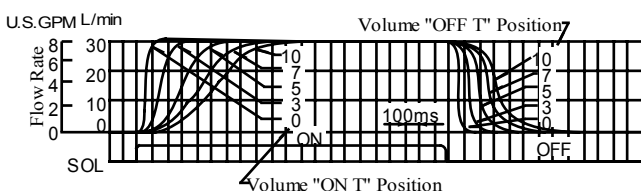

2B7

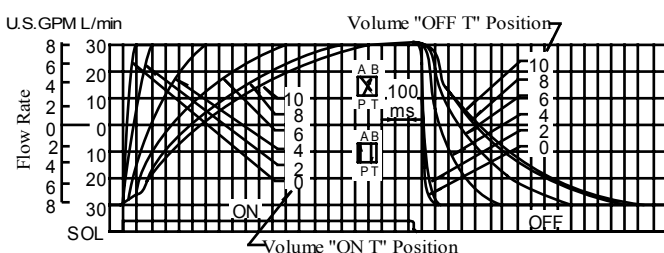

Low Speed Operating Flow Characteristics

Supply Pressure : 16 MPa (2320 PSI)
Flow Rate : 30 L/min (7.9 U.S.GPM)

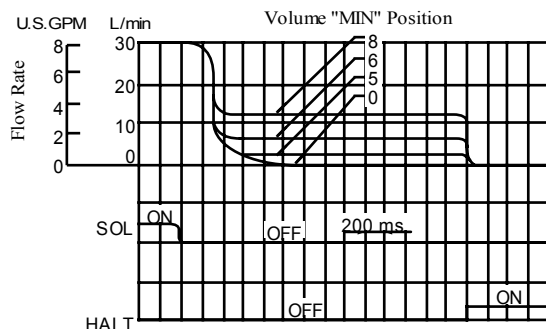

Performance Characteristics

Hydraulic Fluid: Viscosity 30 mm²/s (141 SSU), Specific Gravity 0.850

Maximum Flow Rate

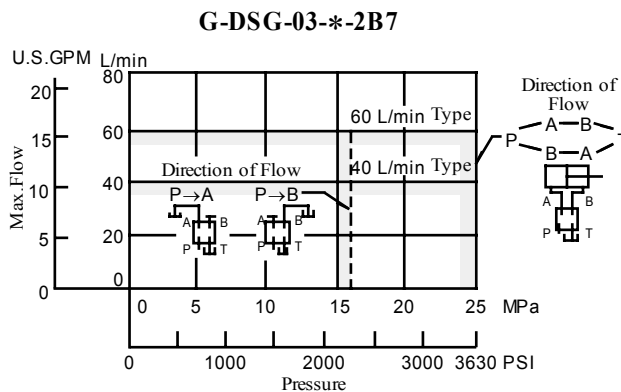
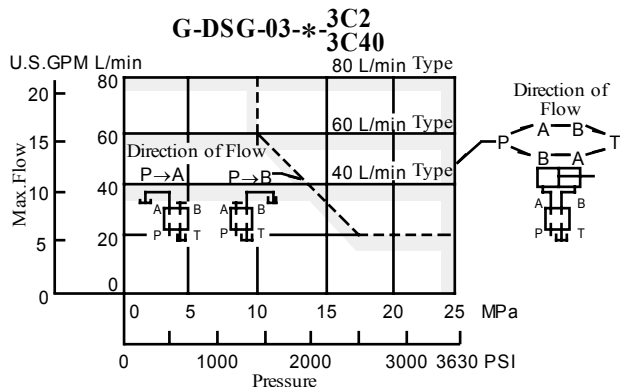

Pressure Drop

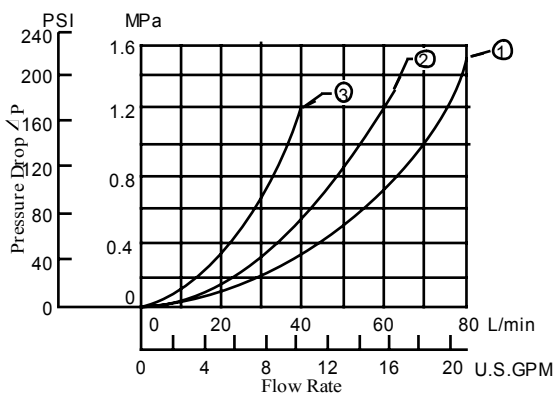

Model Numbers	Pressure Drop Curve Numbers*
G-DSG-03-3C2/3C40	①
G-DSG-03-40-3C2/3C40	③
G-DSG-03-60-3C2/3C40	②
G-DSG-03-2B7	①
G-DSG-03-40-2B7	③

*The numbers of the pressure drop curves are the same for P→A, P→B, A→T and B→T.

- For any other viscosity, multiply the factors in the table right.
- For any other specific gravity (G'), the pressure drop (ΔP') may be obtained from the formula below.

$$\Delta P' = \Delta P (G'/0.850)$$

Viscosity	mm ² /s	15	20	30	40	50	60	70	80	90	100
	SSU		77	98	141	186	232	278	324	371	417
Factor		0.84	0.91	1.00	1.07	1.14	1.19	1.24	1.28	1.32	1.35

Shifting Characteristics

Supply Pressure : 16 MPa (2320 PSI)
Flow Rate : 60 L/min (15.9 U.S. GPM)

● 3C2, 3C40

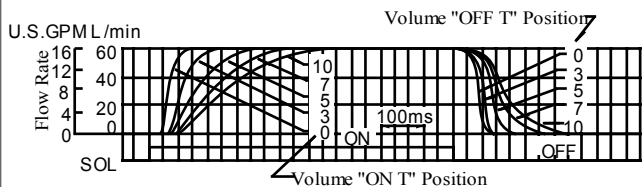

● 2B7

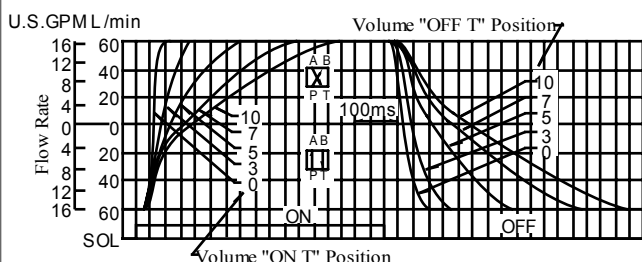

Low Speed Operating Flow Characteristics

Supply Pressure : 16 MPa (2320 PSI)
Flow Rate : 60 L/min (15.9 U.S. GPM)

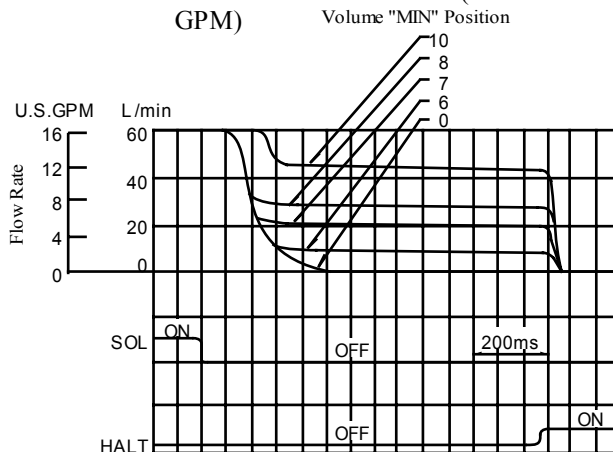

Installation Drawings

Mounting Surface:
ISO 4401-AB-03-4-A

G-DSG-01-* -3C2/3C40-* -50/5090

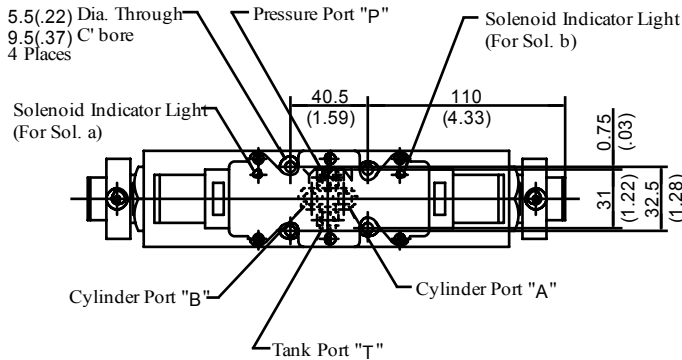

Model Numbers	"C" Thd.
G-DSG-01-***-*-50	G 1/2
G-DSG-01-***-*-5090	1/2 NPT

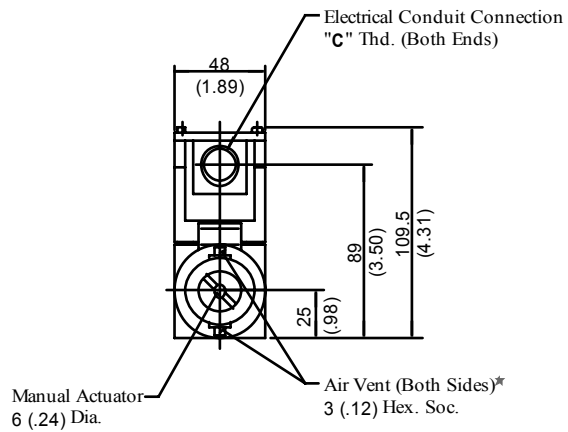
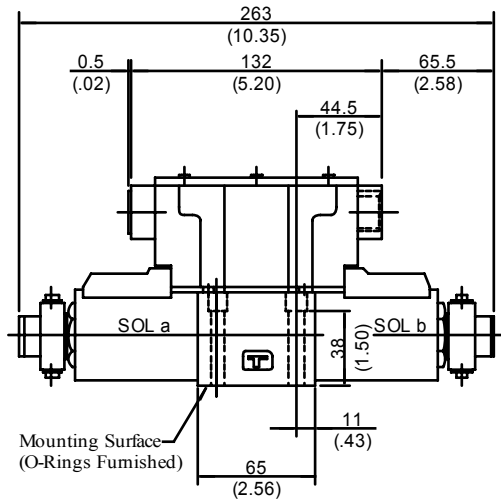

★ Air vent position around valve longitudinal axis can be optionally selected.

DIMENSIONS IN
MILLIMETRES (INCHES)

G-DSG-01-* -2B7-* -50/5090

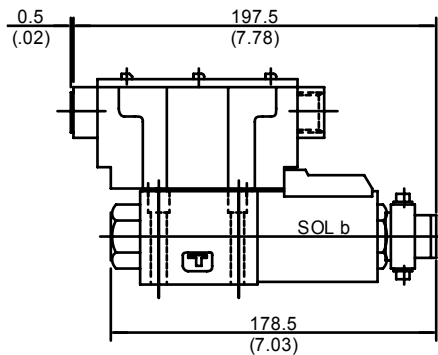

* For other dimensions, refer to the drawing above.



Installation Drawings

Mounting Surface:
ISO 4401-AC-05-4-A

G-DSG-03-* -3C2/3C40-* -50/5090

Model Numbers	"C" Thd.
G-DSG-03-***-50	G 1/2
G-DSG-03-***-5090	1/2 NPT

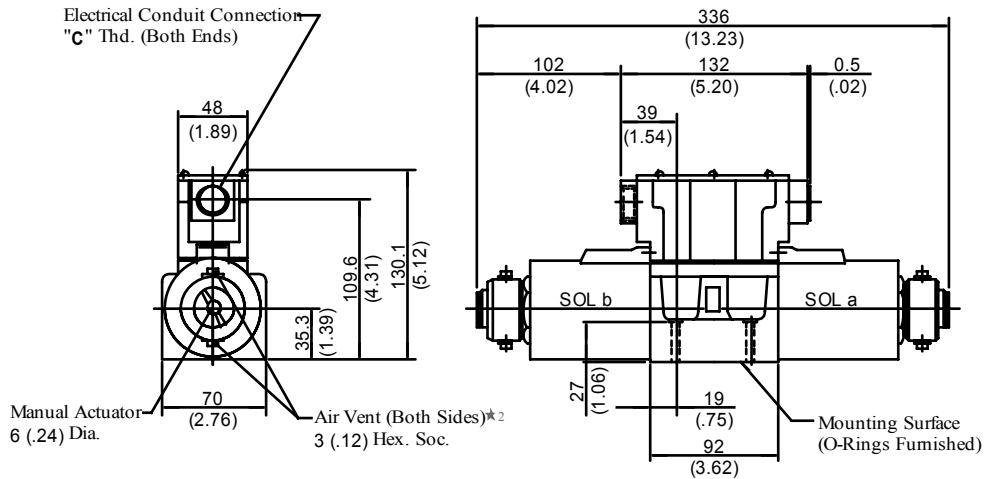
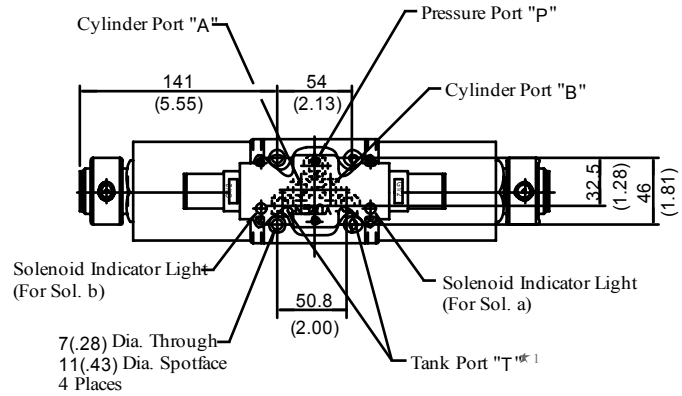

- ★ 1. Although the tank port is shown on the left in our sub-plate, either may be used.
- ★ 2. Air vent position around valve longitudinal axis can be optionally selected.

DIMENSIONS IN
MILLIMETRES (INCHES)

G-DSG-03-* -2B7-* -50/5090

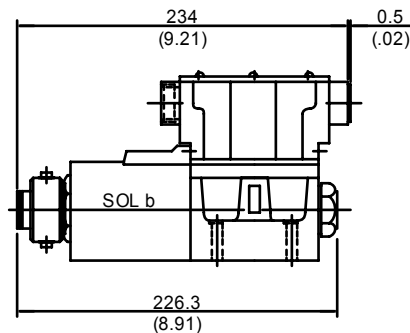

* For other dimensions, refer to the drawing above.

Installation Drawings

DSGM-01*-30/3080/3090

DIMENSIONS IN
MILLIMETRES (INCHES)

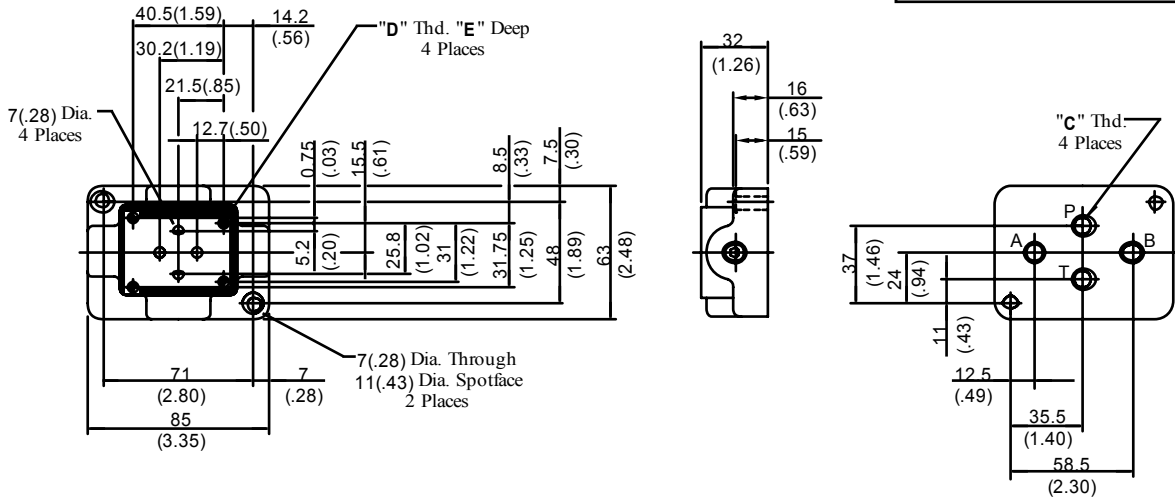

Sub-plate Model Numbers	Thread Size		"E" mm (in.)
	"C" Thd.	"D" Thd.	
DSGM-01-30	Rc 1/8	M5	10 (.39)
DSGM-01-3080	1/8 BSP.F		
DSGM-01-3090	1/8 NPT	No.10-24 UNC	12 (.47)
DSGM-01X-30	Rc 1/4	M5	10 (.39)
DSGM-01X-3080	1/4 BSP.F		
DSGM-01X-3090	1/4 NPT	No.10-24 UNC	12 (.47)
DSGM-01Y-30	Rc 3/8	M5	10 (.39)
DSGM-01Y-3090	3/8 NPT	No.10-24 UNC	12 (.47)



DSGM-03*-40/2180/2190

DIMENSIONS IN
MILLIMETRES (INCHES)

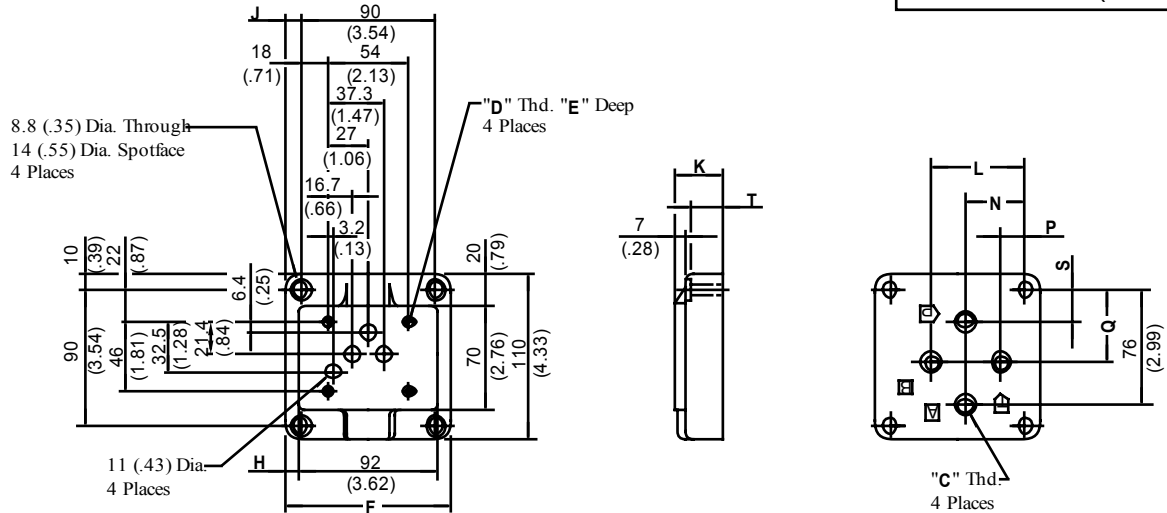

Sub-plate Model Numbers	Thread Size		Dimensions mm (Inches)										
	"C" Thd.	"D" Thd.	E	F	H	J	K	L	N	P	Q	S	T
DSGM-03-40	Rc 3/8	M6	13 (.51)	110	9	10	32	62	40	16	48	21	24
DSGM-03-2180	3/8 BSP.F		(4.33)	(.35)	(.39)	(1.26)	(2.44)	(1.57)	(.63)	(1.89)	(.83)	(.94)	
DSGM-03-2190	3/8 NPT		1/4-20 UNC	15 (.59)									
DSGM-03X-40	Rc 1/2	M6	13 (.51)	110	9	10	32	62	40	16	48	21	24
DSGM-03X-2180	1/2 BSP.F		(4.33)	(.35)	(.39)	(1.26)	(2.44)	(1.57)	(.63)	(1.89)	(.83)	(.94)	
DSGM-03X-2190	1/2 NPT		1/4-20 UNC	15 (.59)									
DSGM-03Y-40	Rc 3/4	M6	13 (.51)	120	14	15	50	80	45	10	47	16	42
DSGM-03Y-2180	3/4 BSP.F		(4.72)	(.55)	(.59)	(1.97)	(3.15)	(1.77)	(.39)	(1.85)	(.63)	(1.65)	
DSGM-03Y-2190	3/4 NPT		1/4-20 UNC	15 (.59)									

**"G" Series Shockless Type
Solenoid Controlled Pilot Operated
Directional Valves
G-DSHG-04/06
Sub-plate Mounting**

Specifications

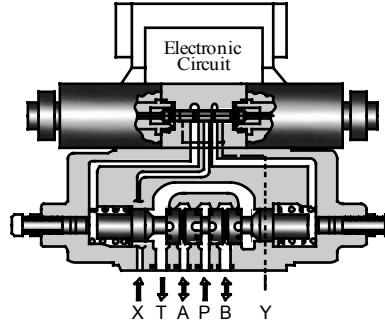

■ Specifications



Descriptions		Model Numbers	G-DSHG-04-3C*-**-*-50/5090	G-DSHG-06-3C*-**-*-50/5090
Max. Flow	L/m in (U.S.GPM)		160 (42.3) ^{★1}	250 (66.1) ^{★1}
Max. Operating Pres.	MPa (PSI)		25 (3630)	25 (3630)
Max. T-Line Back Pres.	MPa (PSI)		16 (2320)	16 (2320)
Max. Drain Line Back Pressure	MPa (PSI)		3 (440)	3 (440)
Max. Pilot Pressure	MPa (PSI)		16 (2320)	16 (2320)
Min. Required Pilot Pres.	MPa (PSI)		1.5 (220) ^{★2}	
Pilot Flow L/m in (U.S.GPM)	at Normal		1 (0.3)	1 (0.3)
	at Transition		4 (1.1)	6 (1.6)
Electric Power Supply	Voltage		24 V DC (21 - 28 V DC Included Ripple): Use a stable power supply	
	Input Power at 24V		36 W	36 W
Shifting signal, low speed operation halt signal (can be used in com m on with electric power supply)	Voltage		5 - 48 V DC (Use a stable power supply)	
	Current		Constant at 10 mA (A constant-current circuit is used)	
	Input interface		Sink Type, Source Type	
Shifting time range (for ON and OFF)			ON: 0.06 - 1.5 s, OFF: 0.1 - 2 s	ON: 0.1 - 1 s, OFF: 0.2 - 2 s
Low speed operation flow rate (min. flow rate) range (for SOL a and b) L/min (U.S.GPM)			5 - 20 (1.3 - 5.3)	10 - 30 (2.6 - 7.9)
Low speed operation flow rate (min. flow rate) hold time			Max. 60 s (After 60 seconds, the flow rate decreases gradually.)	
Ambient Temperature			0 - 50 °C (32 - 122 °F) with circulated air	
Approx. Mass			12 kg (26.5 lbs.)	15 kg (33.1 lbs.)

★ 1. The maximum flow rate is constant irrespective of the working pressure.

★ 2. Be sure that the difference between pilot pressure and drain port backpressure is larger than the minimum pilot pressure.



Model Number Designation

G-DSHG	-04	-3C2	-E	-R2	-S	-50	*
Series Number	Valve Size	Spool Type	Pilot Connection	Spool Control Modification (Omit if not required)	Input Interface	Design Number	Design Standards
G-DSHG: G Series Shockless Type Solenoid Controlled Pilot Operated Directional Valve, Sub-plate Mounting	04	3C2 	None : Internal Pilot	R2: With Stroke Adjustment, Both Ends RA: With Stroke Adjustment, Port "A" End RB: With Stroke Adjustment, Port "B" End	None: Sink Type (Standard) S: Source Type	50	Refer to ★
	06	3C40 	E : External Pilot			50	

★ Design Standards: None Japanese Standard "JIS" and European Design Standard
90 N. American Design Standard

Sub-plate

Valve Model Numbers	Japanese Standard "JIS"			European Design Standard			N. American Design Standard		
	Sub-plate Model Numbers	Thread Size	Approx. Mass kg (lbs.)	Sub-plate Model Numbers	Thread Size	Approx. Mass kg (lbs.)	Sub-plate Model Numbers	Thread Size	Approx. Mass kg (lbs.)
G-DSHG-04	DHGM-04-20	Rc 1/2	4.4 (9.7)	DHGM-04-2080	1/2 BSP.F	4.4 (9.7)	DHGM-04-2090	1/2 NPT	4.4 (9.7)
	DHGM-04X-20	Rc 3/4	4.1 (9.0)	DHGM-04X-2080	3/4 BSP.F	4.1 (9.0)	DHGM-04X-2090	3/4 NPT	4.1 (9.0)
G-DSHG-06	DHGM-06-50	Rc 3/4	7.4 (16.3)	DHGM-06-5080	3/4 BSP.F	8.5 (18.7)	DHGM-06-5090	3/4 NPT	7.4 (16.3)
	DHGM-06X-50	Rc 1	7.4 (16.3)	DHGM-06X-5080	1 BSP.F	8.5 (18.7)	DHGM-06X-5090	1 NPT	7.4 (16.3)

● Sub-plates are available. Specify the sub-plate model number from the table above.
When sub-plates are not used, the mounting surface should have a good machined finish.

Attachment (Mtg. Bolts)

Socket head cap screws in the table below are included.

Model Numbers	Socket Head Cap Screw			
	Japanese Standard "JIS" & European Design Standard	N. American Design Standard	Qty.	Tightening Torque Nm (in. lbs.)
G-DSHG-04	M6 × 45 Lg.	1/4-20 UNC × 1-3/4 Lg. 3/8-16 UNC × 2 Lg.	2	12-15 (106-133)
	M10 × 50 Lg.		4	58-72 (513-637)
G-DSHG-06	M12 × 60 Lg.	1/2-13 UNC × 2-1/2 Lg.	6	100-123 (885-1089)

Performance Characteristics

Hydraulic Fluid: Viscosity 30 mm²/s (141 SSU), Specific Gravity 0.850

■ Pressure Drop

● G-DSHG-04/06-3C2/3C40

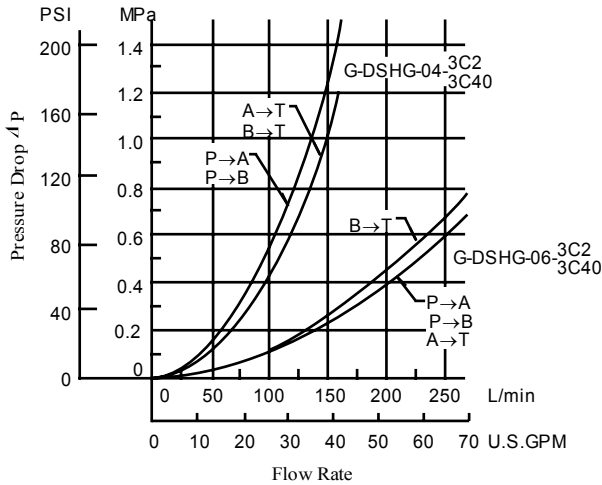

- For any other viscosity, multiply the factors in the table below.

Viscosity	mm ² /s	15	20	30	40	50	60	70	80	90	100
	SSU		77	98	141	186	232	278	324	371	417
Factor		0.84	0.91	1.00	1.07	1.14	1.19	1.24	1.28	1.32	1.35

- For any other specific gravity (G'), the pressure drop ($\Delta P'$) may be obtained from the formula below.
 $\Delta P' = \Delta P (G'/0.850)$

■ Shifting Characteristics

● G-DSHG-04-3C2/3C40

Supply Pressure : 16 MPa (2320 PSI)
Flow Rate : 150 L/min (39.6 U.S.GPM)
Pilot Pressure : 16 MPa (2320 PSI)

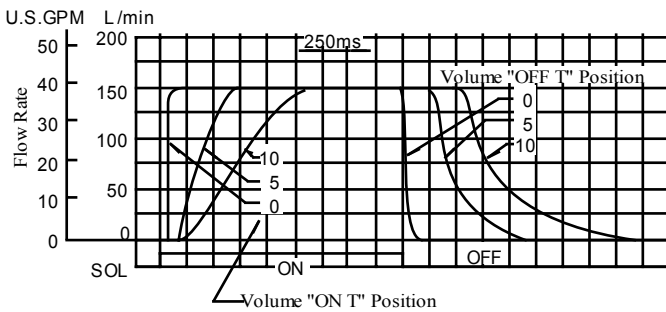

● G-DSHG-06-3C2/3C40

Supply Pressure : 16 MPa (2320 PSI)
Flow Rate : 250 L/min (66.1 U.S.GPM)
Pilot Pressure : 16 MPa (2320 PSI)

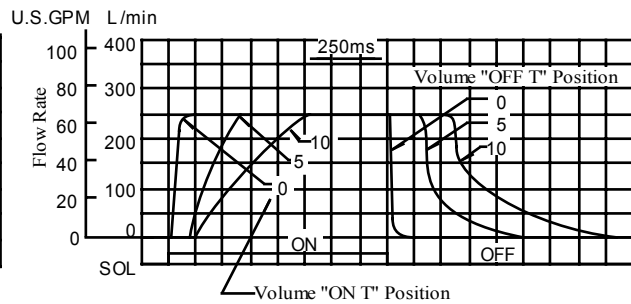

■ Low Speed Operating Flow Characteristics

● G-DSHG-04-3C2/3C40

Supply Pressure : 16 MPa (2320 PSI)
Flow Rate : 150 L/min (39.6 U.S.GPM)
Pilot Pressure : 16 MPa (2320 PSI)

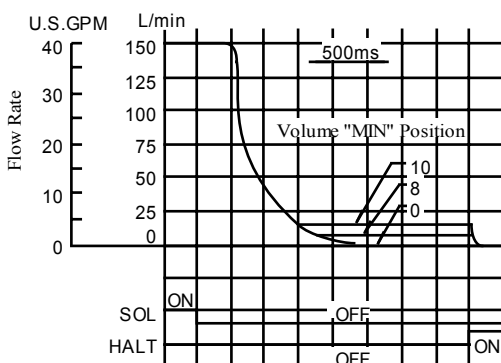

● G-DSHG-06-3C2/3C40

Supply Pressure : 16 MPa (2320 PSI)
Flow Rate : 250 L/min (66.1 U.S.GPM)
Pilot Pressure : 16 MPa (2320 PSI)

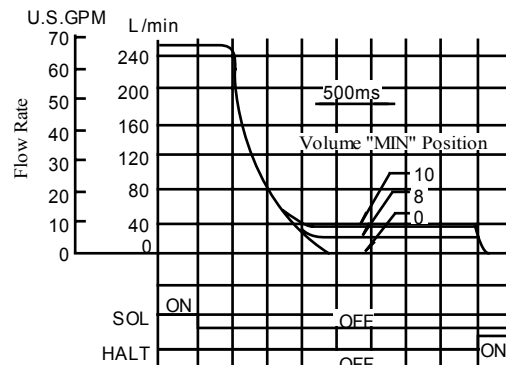

"G" Series Shockless Type Solenoid Controlled Pilot Operated Directional Valves G-DSHG-04

Installation Drawings

G-DSHG-04-3C*-*-50/5090

Mounting Surface:
ISO 4401-AD-07-4-A

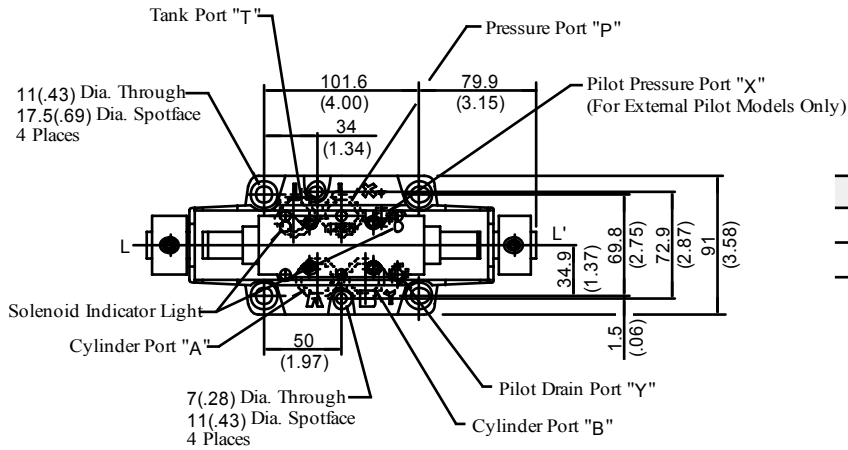

Model Numbers	"C" Thd.
G-DSHG-04-3C*-*-50	G 1/2
G-DSHG-04-3C*-*-5090	1/2 NPT

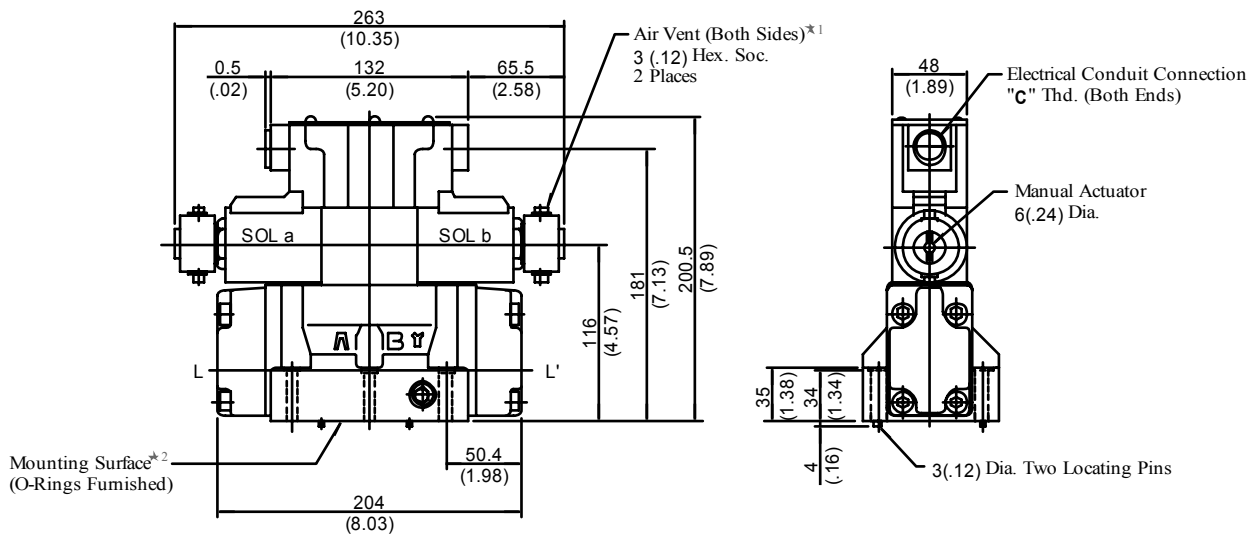

★ 1. Air vent position around valve longitudinal axis can be optionally selected.

★ 2. O-rings for ports: SO-NB-P22 for P/A/B/T ports
SO-NB-P9 for X/Y ports

DIMENSIONS IN
MILLIMETRES (INCHES)

● Models with Stroke Adjustment (Option)

G-DSHG-04-3C*-*-R*-*-50/5090

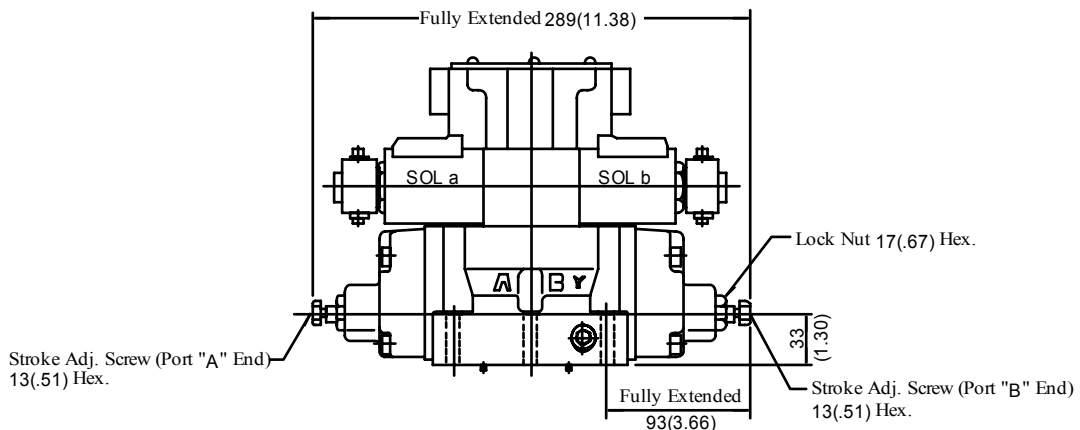

"G" Series Shockless Type Solenoid Controlled Pilot Operated Directional Valves G-DSHG-06

Installation Drawings

Mounting Surface:
ISO 4401-AE-08-4-A

G-DSHG-06-3C*- *- *-50/5090

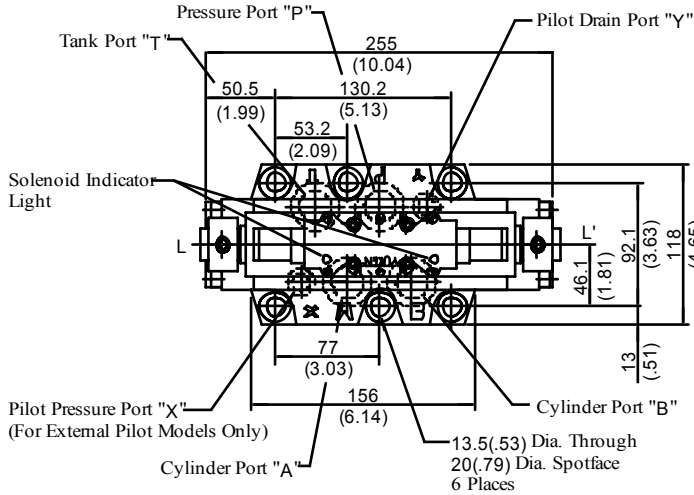

Model Numbers	"C" Thd.
G-DSHG-06-3C*- *- *-50	G 1/2
G-DSHG-06-3C*- *- *-5090	1/2 NPT

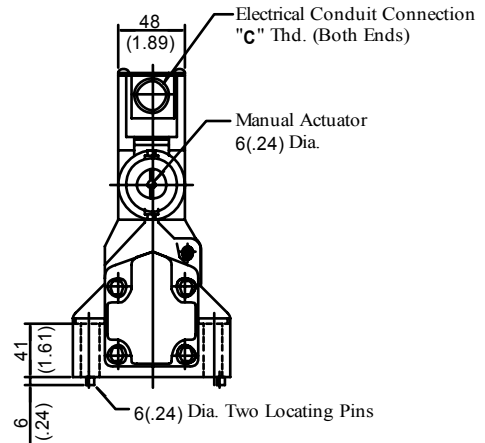
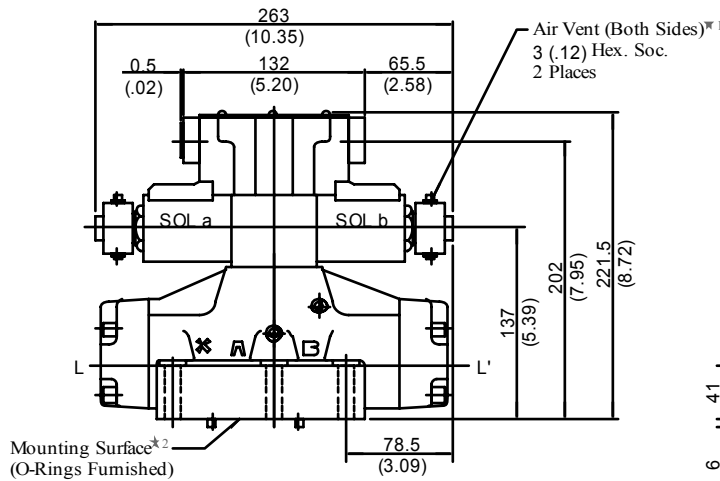

- ★ 1. Air vent position around valve longitudinal axis can be optionally selected.
- ★ 2. O-rings for ports: SO-NB-P30 for P/A/B/T ports
SO-NB-P14 for X/Y ports

DIMENSIONS IN
MILLIMETRES (INCHES)

● Models with Stroke Adjustment (Option)

G-DSHG-06-3C*- *-R*- *-50/5090

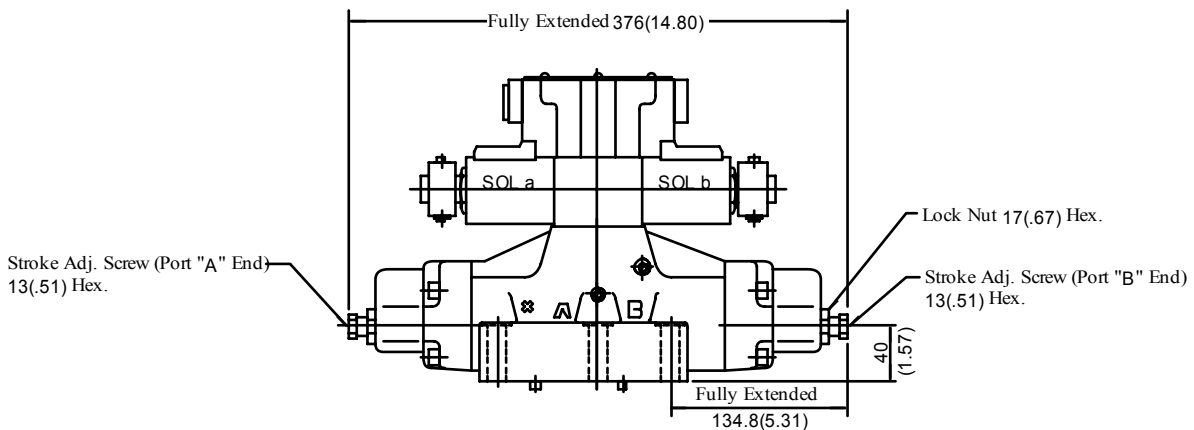

Sub-plate for "G" Series Shockless Type Solenoid Controlled Pilot Operated Directional Valves

Installation Drawings

● DHGM-04
04X20/2080/2090

DIMENSIONS IN
MILLIMETRES (INCHES)

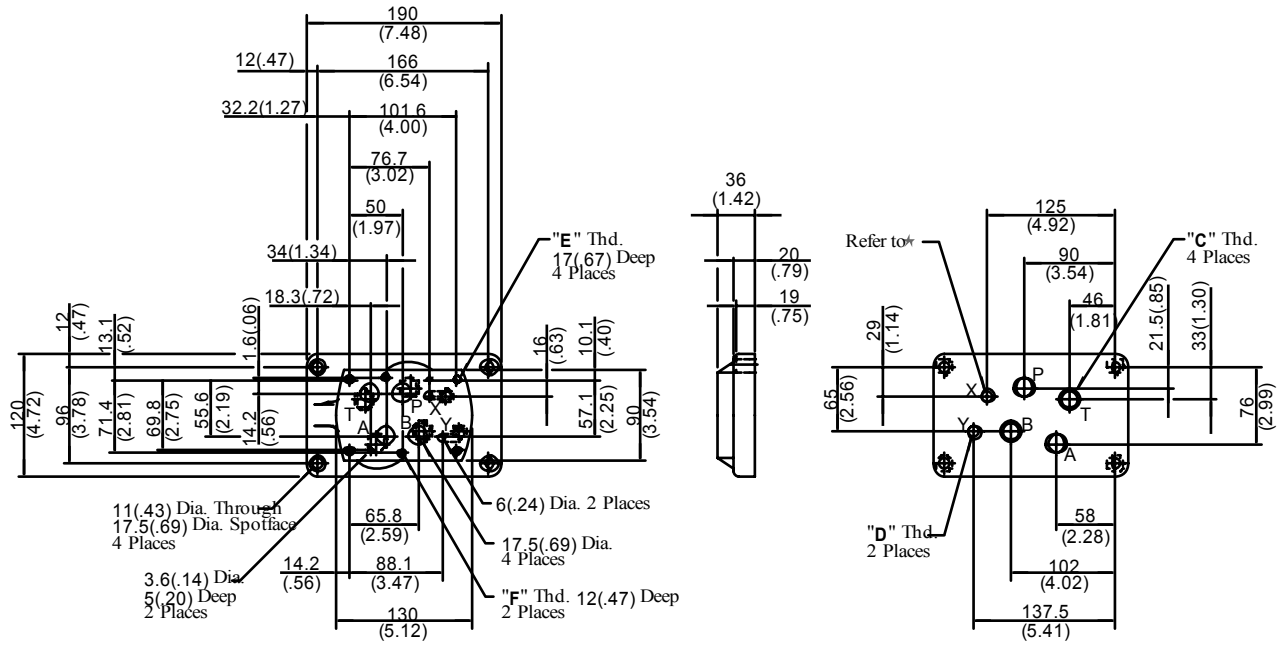

★ Used only on external pilot type valves. To be plugged on internal pilot type valves.

Sub-plate Model Numbers	"C" Thd.	"D" Thd.	"E" Thd.	"F" Thd.
DHGM-04-20	Rc 1/2	Rc 1/4	M10	M6
DHGM-04X-20	Rc 3/4			
DHGM-04-2080	1/2 BSP.F	1/4 BSP.F		
DHGM-04X-2080	3/4 BSP.F			
DHGM-04-2090	1/2 NPT	1/4 NPT	3/8-16 UNC	1/4-20 UNC
DHGM-04X-2090	3/4 NPT			

Sub-plate for "G" Series Shockless Type Solenoid Controlled Pilot Operated Directional Valves

Installation Drawings

● DHGM-06 06X50/5090

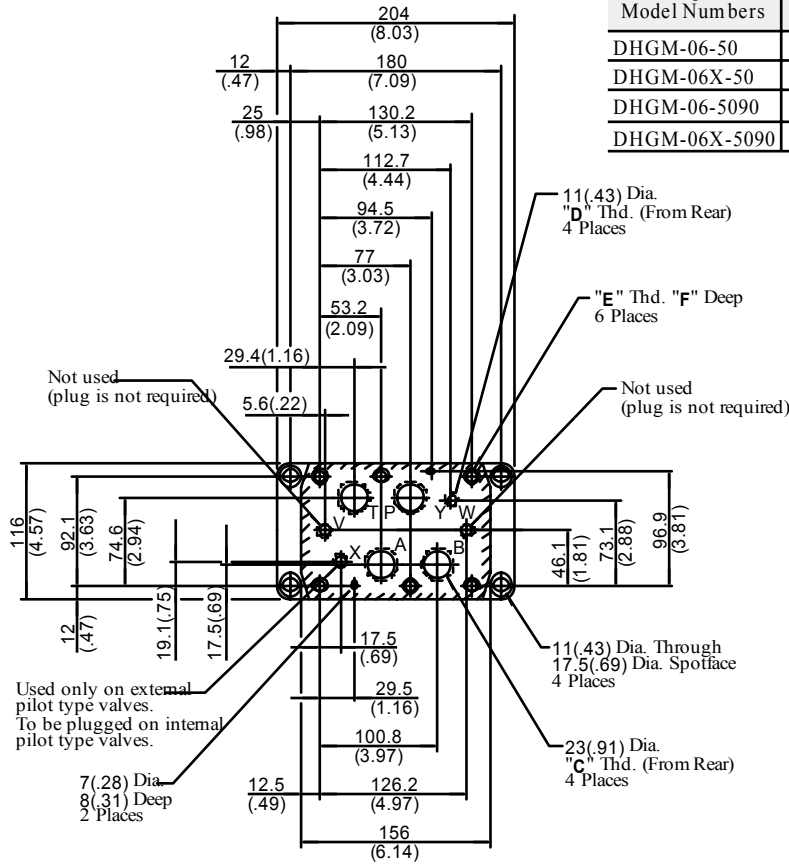

Sub-plate Model Numbers	"C" Thd.	"D" Thd.	"E" Thd.	F mm (in.)
DHGM-06-50	Rc 3/4	Rc 1/4	M12	24 (.94)
DHGM-06X-50	Rc 1			
DHGM-06-5090	3/4 NPT	1/4 NPT	1/2-13 UNC	26 (1.02)
DHGM-06X-5090	1 NPT			

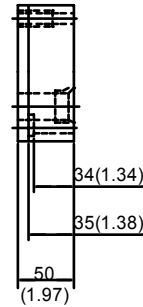

DIMENSIONS IN MILLIMETRES (INCHES)

● DHGM-06 06X5080

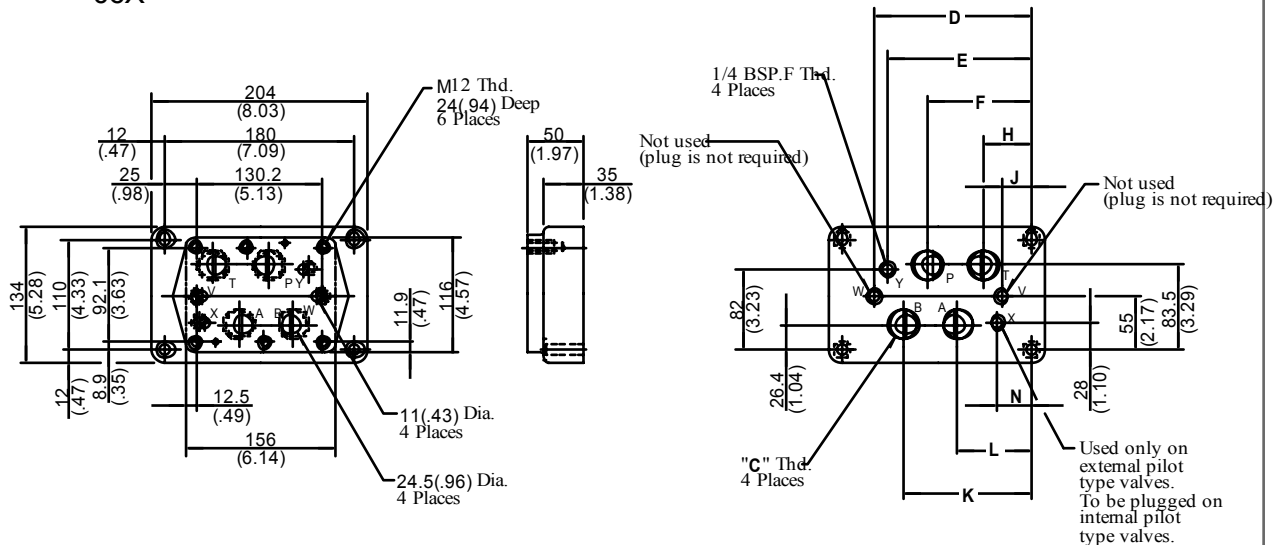

Sub-plate Model Numbers	"C" Thd.	Dimensions mm (Inches)							
		D	E	F	H	J	K	L	N
DHGM-06-5080	3/4 BSP.F	151.2 (5.95)	137.7 (5.42)	102 (4.02)	54.4 (2.14)	30.6 (1.20)	125.8 (4.95)	78.2 (3.08)	42.5 (1.67)
DHGM-06X-5080	1 BSP.F	155.2 (6.11)	148 (5.83)	106 (4.17)	50 (1.97)	25 (.98)	130 (5.12)	74 (2.91)	32 (1.26)

For other dimensions, refer to "DHGM-06*-50/5090" above.

